



# AIR CIRCUIT BREAKER





# Contents

<b>1. Introduction</b>	<b>1</b>
1.1 Purposes	1
1.2 Type designation	1
1.3 Feature	1
1.4 Classification	1
1.5 Conditions of use	1
<b>2. Structure specifications</b>	<b>2</b>
<b>3. Specification</b>	<b>3</b>
3.1 Specification	3
3.2 Accessory Specification	4
<b>4. Intelligent Controller</b>	<b>5</b>
4.1 Specification	5
4.2 Function Table	6
4.3 Protection Characteristics	7
4.3.1 Technical parameters	7
4.3.2 AIC-H other function	14
4.3.3 Display Measurement Parameter	17
4.3.4 Other functions	19
<b>5. Characteristic Curves</b>	<b>22</b>
5.1 Overload(EIT) 、 Short-circuit 、 Instantaneous protection	22
5.2 Five Tripping Curves (EIT 、 SIT 、 VIT 、 DT 、 HVF)	23
5.3 Ground fault protection	23
5.4 Leakage protection	24
<b>6. Intelligent Controller Usage</b>	<b>25</b>
6.1 Panel Schematic Diagram	25
6.2 Page Description	27
6.2.1 Measurement Page	27
6.2.2 Parameter page	31
6.2.3 Maintenance page	34
6.2.4 Testing page	35
6.2.5 Language, communication page	35
6.2.6 Record page	36
6.3 Factory setting	37
<b>7. Secondary Wiring Diagram</b>	<b>39</b>
7.1 Controller and Circuit Breaker Wiring	39
7.2 Secondary Wiring Diagram	40
7.2.1 AIC-E/A Type Controller	40
7.2.2 AIC-H Type Controller	40
7.2.3 Remote Control Secondary Wiring	41
<b>8. Accessories and functions</b>	<b>42</b>
8.1 Mechanical interlock	42
8.2 Door Frame	43
8.3 Door Interlock	43
8.4 Under voltage release	43
8.5 Power Module	44
8.6 External sensor for neutral conductor (for 3P+N)	44
8.7 Zero-phase sequence current sensor (ZCT)	45
8.8 External units of transformer's center	45
<b>9. Safety Distance</b>	<b>47</b>
<b>10. Temperature Compensate</b>	<b>47</b>
<b>11. Busbar Dimension</b>	<b>47</b>
<b>12. Outline and Installation Dimensions</b>	<b>48</b>
12.1 Draw out type	48
12.2 Fixed type	49
<b>13. Mounting, Usage, and Maintenance</b>	<b>50</b>
13.1 Mounting	50
13.2 Commonly Problem and Trouble-shooting	51

## 1. Introduction

### 1.1 Purposes

BW-1600 series air circuit breakers(referred to as circuit breaker) are used in rated voltage AC720V and below, 50/60Hz distribution system, with rated current from 400A to 1600A. It's used for distributing power and protecting circuits in the electrical distribution system is protected from overloading, short circuit, ground fault, and other hazardous faults. The protective actions have a high precision for preventing unnecessary power failure, closing power supply much more reliable.

### 1.2 Type Designation

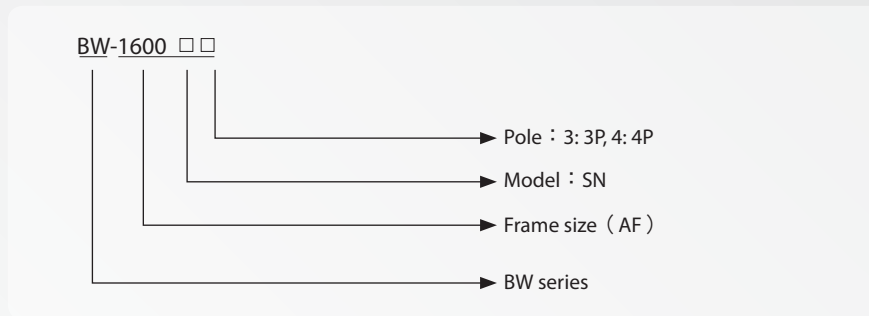

### 1.3 Feature

- Compact structure, smaller size
- High breaking capacity
- No arcing distance, high security
- Intelligent protection and network communication
- Energy measurement, harmonic analysis
- Wiring direction does not affect product.

### 1.4 Classification

- Installation type: Draw-out, fixed type
- Operation mode: Electric and manual operation
- Connection: Horizontal
- Pole: 3P, 4P
- Accessory: Intelligent tripping unit, Under-voltage release, Shunt release

### 1.5 Conditions of use

- Ambient temperature :  $-25^{\circ}\text{C} \sim +70^{\circ}\text{C}$  , E type can be use at  $-40^{\circ}\text{C}$  .  
 Note: (1) If the ambient temperature exceed  $40^{\circ}\text{C}$  , should consider derating.  
 (2) If the ambient temperature exceed above range, please notify us when ordering the product
- The product cannot be installed at places above 2000m altitude.
- Atmospheric conditions: Relative humidity could not exceed 50% when the surrounding temperature is  $+40^{\circ}\text{C}$  .  
 For lower temperature, the relative humidity can be higher. The average maximum relative humidity for the month with the highest humidity is 90%, and the average lowest temperature of that month is  $+25^{\circ}\text{C}$  . Please consider the possibility of frosting on the surface of the product due to temperature change.
- Pollution level: 3
- Mounting conditions: Consult this manual for circuit breaker installation.
- Wiring: Can be reverse wiring.

## 2. Structure Specifications

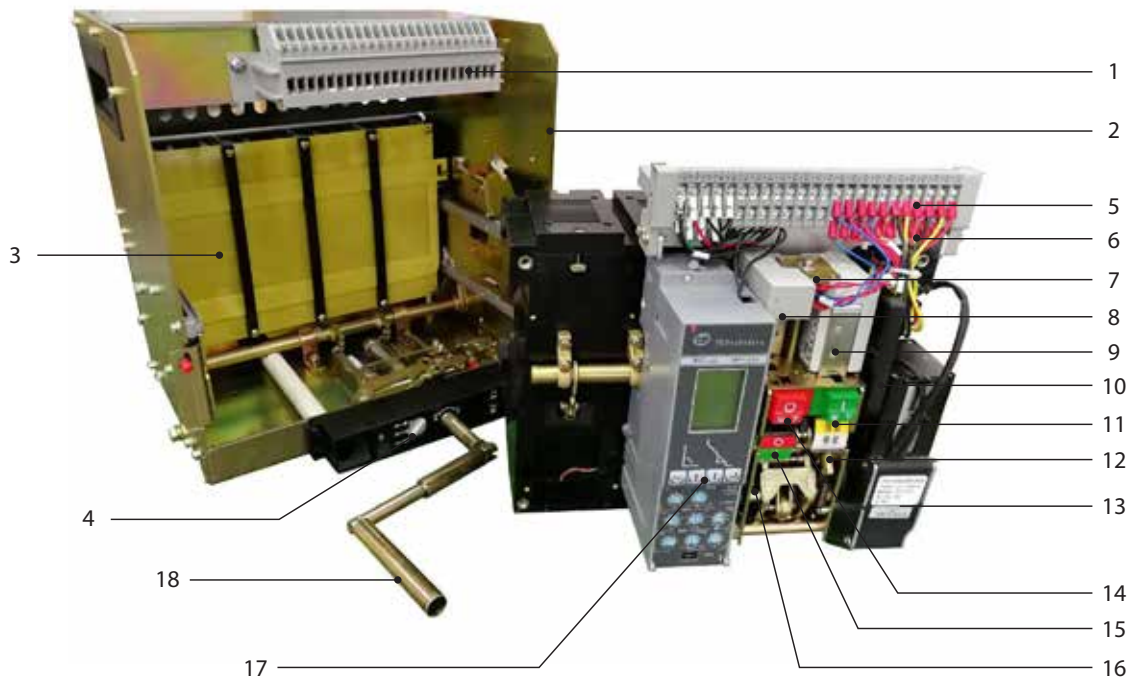

1. Secondary circuit terminal (Fixed)
2. Cradle
3. Safety baffle
4. Position indicator
5. Secondary circuit terminal (Moving)
6. Auxiliary contacts
7. Shunt release
8. Under-voltage release
9. Closing release
10. Operation handle
11. Closing button
12. Energy storage status indicator
13. Gear motor
14. Open button
15. Contact position indicator
16. Mechanism
17. Intelligent controller
18. Handle
19. Cover

## 3. Specification

### 3.1 Specification



Frame Size		1600AF	
Rated Current, In (A)		400、630、800、1000	1250、1600
Rated Voltage, Ue		AC690 / 720V、AC400 / 415V	
Insulation Voltage, Ui		AC1000V	
Rated Impulse Withstand Voltage, Uimp		12kV	
Pole		3P、4P	
Rated Current of Neutral (%)		100%In	
Breaking Capacity	Model		SN
	Icu / Ics (kA)	AC400V / 415V	65 / 65
		AC690V / 720V	50 / 50
	Icw (kA) 1sec		50
	Icm (kA)	AC400V / 415V	143
		AC690V / 720V	105
Arcing distance (mm)		0	
Max. total breaking time (s)		≤30	
Max. closing time (ms)		≤70	
Endurance (20times /h)	Electrical	AC400V	10000
		AC690V	6500
	Mechanical	Without maintenance	15000
		With maintenance	20000
Dimension (mm) (H × W × D)	Fixed Type	3P	312 × 265 × 201
		4P	312 × 335 × 201
	Draw out Type	3P	345 × 275 × 300
		4P	345 × 345 × 300

### 3.2 Accessory Specification

Rated voltage		AC50Hz		DC		
		220~240V	400V / 415V	220V	110V	
Closing release	Power consumption	24VA	36VA	24W		
	Operating voltage range	(0.85~1.1) Us				
Shunt release	Power consumption	24VA	36VA	24W		
	Operating voltage range	(0.7~1.1) Us				
Motor gear	Power consumption	50VA		50W		
	Operating voltage range	(0.85 ~ 1.1) Us				
Under voltage release	Operating time	Delay: 1s / 3s / 5s Instantaneous		—		
	Power consumption	24VA	36VA			
	Operating voltage range	(35%~70%) Ue	Break the circuit breaker			
		<35% Ue	Circuit breaker cannot closed			
		(85%~110%) Ue	Reliable close the circuit breaker			
Operating voltage up to 85% Ue in 1/2 delay time	No break of circuit breaker					
Auxiliary contacts	Type	4NO4NC				
	Thermal rated current of auxiliary contact	6A				
	Power consumption	300VA		60W		

## 4. Intelligent Controller

### 4.1 Specification

	Type	Protection		Optional		Other function
	AIC-E	G				
	Standard	O	Overcurrent (LSI)			<ul style="list-style-type: none"> <li>● MCR protection</li> <li>● Thermal memory</li> <li>● Over temperature indicator</li> </ul>
	AIC-A	G		N/A		
	Current type	O	Overcurrent (LSI)			<ul style="list-style-type: none"> <li>● LCD display</li> <li>● Fault record history</li> <li>● Current-unbalance</li> <li>● Test function</li> </ul>
	G	Ground fault (vector sum)				
	W	Ground fault (Source Ground Return)				
	F	Earth leakage + ZCT (note 2)				
	AIC-H	G		C		
	Harmonic type	O	Overcurrent (LSI)	C	N/A	<ul style="list-style-type: none"> <li>● ZSI protection</li> <li>● Voltage protection</li> <li>● Frequency protection</li> <li>● Power and energy</li> <li>● Harmonic analysis</li> <li>● Load monitor</li> <li>● Four-set signal output</li> </ul>
	G	Ground fault (vector sum)				
	W	Ground fault (Source Ground Return)				
	F	Earth leakage + ZCT				

Note: 1. Earth grounding (Source Ground Return) function must pair with external sensor of transformer's center and external module of transformer's center.

2. Earth leakage function must pair with a ZCT.



## 4.2 Function Table

Frame Size 1600AF		Controller		
		AIC-E	AIC-A	AIC-H
Protection and alarm	Overload long-time delay protection EIT	■	■	■
	5 overload characteristics curves selection		■	■
	Short-circuit, short-time delay protection	■	■	■
	Instantaneous protection	■	■	■
	Ground fault protection	□	□	□
	Earth leakage protection		□	□
	Ground fault alarm (note 1)		□	□
	Earth leakage alarm		□	□
	Overload pre-alarm	■	■	■
	MCR Protection	■	■	■
	Neutral protection	■	■	■
	Load monitor			■
	Thermal memory functions	■	■	■
	Current-unbalance		■	■
	Voltage-unbalance			■
	Over (under) voltage			■
	Over (under) frequency			■
	Phase sequence			■
	Reverse Power			■
	Demand current			■
ZSI (Zone selective Interlocking)			■	
Measurement and display	Current		■	■
	Current unbalance		■	■
	Voltage			■
	Voltage unbalance			■
	Frequency			■
	Phase sequence			■
	Power			■
	Energy			■
	Demand Current			■
	Demand Power			■
Harmonic			■	
Maintenance	Over-temperature	■	■	■
	Contact wear indication		■	■
	Refuse action	■	■	■
History and Record	Trip record		■	■
	Alarm record		■	■
	Trip times		■	■
	Operation counter		■	■
	Position Change record		■	■
Others	Four-set signal output			■
	Self-testing		■	■
	Communication			□

■ Standard □ Option

Note 1 : Notification by LED indicator only for AIC-E/AIC-A controller. Signal output support for AIC-H controller.

## 4.3 Protection Characteristics

### 4.3.1 Technical parameters

#### ■ Overload Protection EIT ( AIC-E )

Overload long-time delay protection	Current setting	$I_r=(0.4\sim 1) I_n$	Adjust range: Iu:0.4-0.45-0.5-0.55-0.6-0.65 -0.7-0.75-0.8-0.85-0.9-0.95In Ir:0-0.005-0.01-0.015-0.02-0.025 -0.03-0.035-0.04-0.045-0.05In +Iu
	Operation characteristics	Trip at 1.05~1.2Ir	
	Time delay	$T_r=0.5\sim 24s@6I_r$	0.5-1-2-4-8-12-16-20-24
	Accuracy	±20%	
Thermal memory	30min ( factory default)		

#### ■ Overload Protection ( 5characteristic curves, AIC-A/AIC-H )

Overload long-time delay protection	Current setting	$I_r = (0.4\sim 1) I_n$	Adjust range: Iu:0.4-0.45-0.5-0.55-0.6-0.65 -0.7-0.75-0.8-0.85-0.9-0.95In Ir:0-0.005-0.01-0.015-0.02-0.025 -0.03-0.035-0.04-0.045-0.05In +Iu
	Operation characteristics	Trip at 1.05~1.2Ir	
	Time delay	$T_r = 0.5\sim 24s@6I_r$	0.5-1-2-4-8-12-16-20-24 note 1
	Accuracy	±20%	
	Tripping curve	EIT-DT-SIT-VIT-HVF	
Thermal memory	30min (Can be disabled)		

#### ■ Overload long-time delay protection characteristics

Characteristics	Current ratio (I/I <sub>r</sub> )	Trip Time
No trip	≤1.05	≥2h no trip
Trip	>1.2	<2h trip

Note: 1.Maximum  $T_r$  setting value=4s when tripping-curve is set to HVF.

2. When  $T_r=0.5s$  or  $T_r=1s$ , short-circuit short time delay protection is set to definite time.

3. When fault current  $I \geq 10I_r$ , operation time is same as  $I=10I_r$ .

**Overload long time delay protection characteristics (s):**

EIT		0.5	1	2	4	8	12	16	20	24
Time delay (s)	1.5×I <sub>r</sub>	14	28	56	112	224	336	448	560	672
	2×I <sub>r</sub>	5.83	11.67	23.33	46.67	93.3	140	186.7	233.3	280
	6×I <sub>r</sub>	0.5	1	2	4	8	12	16	20	24
	7.2×I <sub>r</sub>	0.5	0.69	1.38	2.75	5.51	8.26	11.01	13.77	16.52
	10×I <sub>r</sub>	0.5	0.50	0.71	1.41	2.83	4.24	5.66	7.07	8.48
DT		0.5	1	2	4	8	12	16	20	24
Delay time (s)	1.5×I <sub>r</sub>	0.5	1	2	4	8	12	16	20	24
	2×I <sub>r</sub>	0.5	1	2	4	8	12	16	20	24
	6×I <sub>r</sub>	0.5	1	2	4	8	12	16	20	24
	7.2×I <sub>r</sub>	0.5	1	2	4	8	12	16	20	24
	10×I <sub>r</sub>	0.5	1	2	4	8	12	16	20	24
SIT		0.5	1	2	4	8	12	16	20	24
Delay time (s)	1.5×I <sub>r</sub>	3.23	6.45	12.90	25.81	51.61	77.42	103.23	129.04	154.84
	2×I <sub>r</sub>	1.75	3.50	7.00	14.00	28.00	41.99	55.99	69.99	83.99
	6×I <sub>r</sub>	0.5	1	2	4	8	12	16	20	24
	7.2×I <sub>r</sub>	0.5	0.86	1.72	3.45	6.89	10.34	13.78	17.23	20.67
	10×I <sub>r</sub>	0.5	0.67	1.34	2.68	5.36	8.05	10.73	13.41	16.09
VIT		0.5	1	2	4	8	12	16	20	24
Delay time (s)	1.5×I <sub>r</sub>	5	10	20	40	80	120	160	200	240
	2×I <sub>r</sub>	2.5	5	10	20	40	60	80	100	120
	6×I <sub>r</sub>	0.5	1	2	4	8	12	16	20	24
	7.2×I <sub>r</sub>	0.5	0.81	1.61	3.23	6.45	9.68	12.90	16.13	19.35
	10×I <sub>r</sub>	0.5	0.56	1.11	2.22	4.44	6.67	8.89	11.11	13.33
HVF		0.5	1	2	4	8	12	16	20	24
Delay time (s)	1.5×I <sub>r</sub>	159	319	638	1275	2550	3825	5100	6375	7650
	2×I <sub>r</sub>	43.17	86.33	172.7	345.3	690.7	1036	1381	1727	2072
	6×I <sub>r</sub>	0.5	1	2	4	8	12	16	20	24
	7.2×I <sub>r</sub>	0.50	0.50	0.96	1.93	3.86	5.78	7.71	9.64	11.57
	10×I <sub>r</sub>	0.50	0.50	0.50	0.52	1.04	1.55	2.07	2.59	3.11

Note: EIT: extremely inverse time curve (I<sup>2</sup>t)

DT: definite time curve

SIT: standard inverse time curve (I<sup>0.5</sup>t)

VIT: very inverse time curve (It)

HVF: compatible with high-voltage fuses (I<sup>4</sup>t)

**Short-circuit Short time delay protection characteristics**

Short-circuit, Short-time delay protection	Current setting	$I_{sd} = (1.5 \sim 10) I_r$	Adjust range: 1.5-2-2.5-3-4-5-6-8-10+OFF
	Accuracy	$\pm 10\%$	
	Time delay	$I^2T$ on (Inverse time): $T_{sd} = (0.1 \sim 0.4) s$ $I^2T$ off (Definite time): $T_{sd} = (0 \sim 0.4) s$	Adjust range: $I^2T$ on (Inverse time): 0.1-0.2-0.3-0.4
			$I^2T$ off (Definite time): 0-0.1-0.2-0.3-0.4
	Operation characteristics	Inverse time / Definite time	
	Accuracy	$\pm 20\%$ or $\pm 30ms$ ( $T_{sd}=0s$ , tolerance: $0.06s \pm 30ms$ )	
Thermal memory	AIC-E: 15min ( factory default ) AIC-A/AIC-H: 15min (Can be disabled)		

**Short-circuit short time delay protection characteristics (s):**

M=I/I <sub>r</sub>	T <sub>sd</sub>	S (Inverse time)			
		0.1	0.2	0.3	0.4
10.0		0.10	0.20	0.30	0.40
9.0		0.12	0.25	0.37	0.49
8.0		0.16	0.31	0.47	0.63
7.2		0.19	0.39	0.58	0.77
6.0		0.28	0.56	0.83	1.11
5.0		0.40	0.80	1.20	1.60
4.0		0.63	1.25	1.88	2.50
3.0		1.11	2.22	3.33	4.44
2.0		2.50	5.00	7.50	10.00
1.9		2.77	5.54	8.31	11.08
1.8		3.09	6.17	9.26	12.35
1.7		3.46	6.92	10.38	13.84
1.6		3.91	7.81	11.72	15.63
1.5		4.44	8.89	13.33	17.78

Note: 1.when the fault current is greater than maximum setting (10I<sub>r</sub>), controller will protect according to current definite time setting.

**Short-circuit instantaneous protection characteristics**

Short-circuit instantaneous	Current setting	$I_i = (2 \sim 15) I_n$	Adjust range: 2-4-6-8-10-11-12-15+OFF
	Accuracy	$\pm 15\%$	
	Operating time	$\leq 60ms$	

**Ground fault protection characteristics**

Ground fault protection	Current setting	$I_g = (0.2 \sim 1) I_n$	Adjust range: 0.2-0.3-0.4-0.5-0.6-0.7-0.8-1+OFF
	Accuracy	$\pm 10\%$	
	Time delay	$I^2T$ on (Inverse time): $T_g = (0.1 \sim 0.4) s$ $I^2T$ off (Definite time): $T_g = (0 \sim 0.4) s$	Adjust range: $I^2T$ on (Inverse time): 0.1-0.2-0.3-0.4
			$I^2T$ off (Definite time): 0-0.1-0.2-0.3-0.4
	Operation characteristics	Inverse time / Definite time	
	Accuracy	$\pm 20\%$ or $\pm 30ms$ ( $T_g=0s$ , tolerance: $0.06s \pm 30ms$ )	

There are two kinds of protection modes: Vector sum, Source Ground Return

Vector sum: Measures current between phase line and neutral in a TN-S system. When ground fault occurred, part of the current will flow back to transformer via PE line, causing the current vector sum ( $I_g = I_a + I_b + I_c + I_N$ ) no longer equal to 0, thus detecting ground fault. Adding an external current transformer to 4 poles or the N phase of 3 pole (3P+N) breaker, and pair with an internal sensor to send signal to controller, opening the breaker when ground fault occurred.

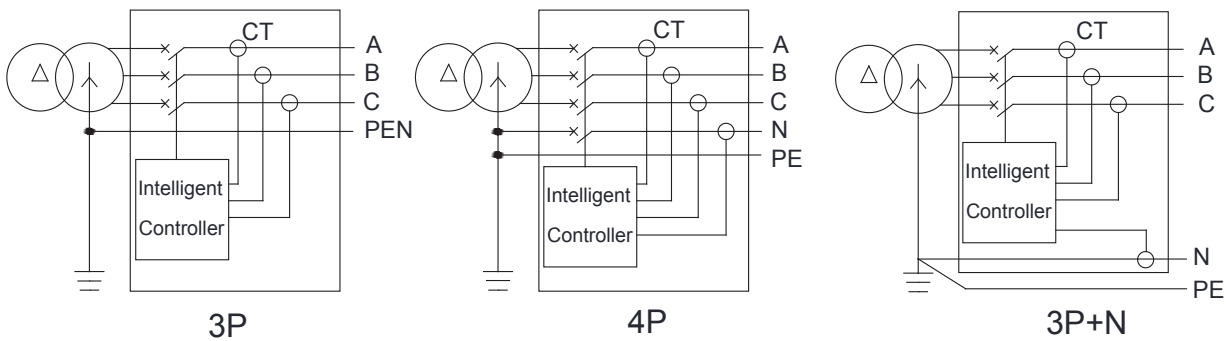

Grounding current: Measure current between phase line and neutral in a TN-S system, measure in the Neutral - earth link of the LV transformer (shown below), when there is a grounding fault, PE line will generate current, causing fault determined.

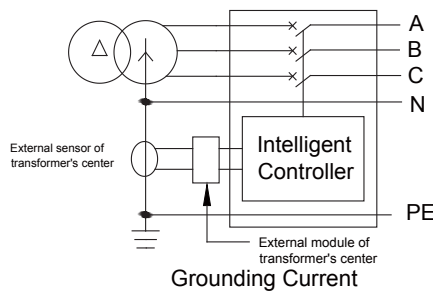

Note: TN-S is 3 phase 5 wires, including A、B、C、N、PE.

ITN-C is 3 phase 4 wires, including A、B、C、PEN. TN-C system does not have grounding protection.

**Ground fault protection characteristics (s):**

M=I/In	Tg	G (Inverse time)			
		0.1	0.2	0.3	0.4
1.0		0.10	0.20	0.30	0.40
0.9		0.12	0.25	0.37	0.49
0.8		0.16	0.31	0.47	0.63
0.7		0.20	0.41	0.61	0.82
0.6		0.28	0.56	0.83	1.11
0.5		0.40	0.80	1.20	1.60
0.4		0.63	1.25	1.88	2.50
0.3		1.11	2.22	3.33	4.44
0.2		2.50	5.00	7.50	10.00

**Earth leakage protection characteristics**

Earth leakage protection	Current setting value	If = 1~30A	Adjust range: 1-2-3-5-7-10-20-30A+OFF
	Accuracy	-20%~0%	
	Delay setting value	Trip: Tf = 0.1~0.8s Alarm: Tf = 0.1~1s	Adjust range: 0.1-0.2-0.4-0.8s
			0.1-0.2-0.4-0.8-1s
	Operation characteristics	Definite time	
	Accuracy	± 10% or ± 30ms(Tf=0.1s, tolerance: 0.1s±30ms)	

Another is transformer mode of external Earth Leakage. The controller gets the output current signal from a current transformer directly to protect. Generally, the secondary output of the transformer is 30A / 300mA.

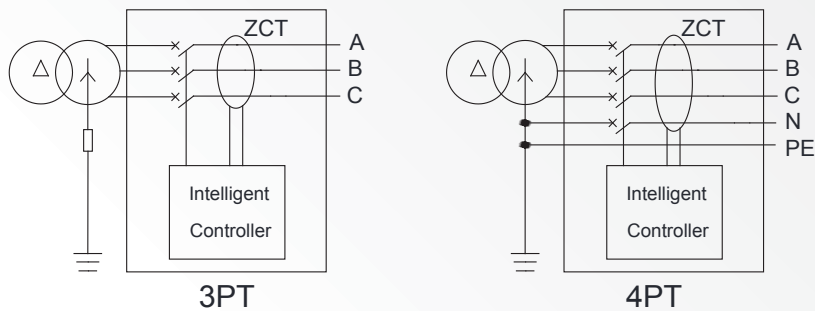

**■ Ground fault alarm/ Earth leakage alarm/ Overload pre-alarm**

Characteristics	Pickup		Dropout	
	Threshold	Time delay	Threshold	Time delay
Ground fault alarm	1.0I <sub>g</sub>	T <sub>g</sub> Inverse / Definite time	0.9I <sub>g</sub>	T <sub>g</sub>
Earth leakage alarm	1.0I <sub>f</sub>	T <sub>f</sub>	0.8I <sub>f</sub>	T <sub>f</sub>
Overload pre-alarm	0.9I <sub>r</sub>	0.1s	0.8I <sub>r</sub>	0.1s

When the current exceeds the pickup threshold, alarm indicators will blink and send the output signal (if function were set); when the current falls below the dropout threshold, alarm function reset.

Note: Notification by LED indicator only for AIC-E / AIC-A controller. Signal output support for AIC-H controller.

**■ MCR Protection**

MCR is a protection for instantaneous short-circuit current when circuit breaker is connected. The breaker will instantaneous trip when a short circuit current ( $\geq 12I_n$ ) occurred during closing operation ( $\leq 100ms$ ), operation time is  $\leq 60ms$ .

MCR	Current setting value	$I_{MCR} = 12I_n$
	Tripping Characteristics	Between $0.85 \sim 1.15 I_{MCR}$
	Operating time	$\leq 60ms$

Note: Within 100ms of closing operation and with external power supply condition.

**■ Neutral protection (N Phase)**

Setting	Type	Description
50%I <sub>r</sub>	Half protection	The overload and short circuit short time delay protection for neutral line will activate with the setting of 50% I <sub>r</sub>
		The instantaneous and ground fault protection for neutral line will activate with the setting of I <sub>r</sub> .
100%I <sub>r</sub>	Full protection	The overload and short circuit short time delay protection for neutral line will activate with the setting of I <sub>r</sub>
		The instantaneous and ground fault protection for neutral line will activate with the setting of I <sub>r</sub> .
OFF	None	Non-neutral wire protection

**■ Thermal Memory Functions**

Repeated overload can heat up the conductor or other devices. The controller can simulate the heating conditions as well as the Overload long-time delay, short-circuit short time delay and other fault or delay actions to generate the thermal effect (simulating characteristics of the double-metal piece). The overload long-time delay thermal effect energy will be completely released in 30 minutes after eliminating the fault. For short-circuit delay thermal effect energy, it will be completely released in 15 minutes after eliminating the fault. During the period, the delay time will be shortened if the reclosing circuit breaker has overload long-time delay or short circuit short-time delay. This is to provide circuits and devices better protection.

**Current Unbalance Protection**

Current unbalance protection is to protect when loss of phase or unbalance of phase current, the protection is based on unbalance percentage.

When the 3 phase current unbalance is greater than Pickup threshold and time, the breaker will trip or send out alarm signal. When the protection type is set to alarm, alarm signal will disarm when the unbalance value is less than Pickup threshold and time.

Current unbalance calculation:

$$I_{unbal} = \frac{I \Delta_{max}}{I_{avg}} \times 100\%$$

$$I_{avg} = \frac{I_a + I_b + I_c}{3}$$

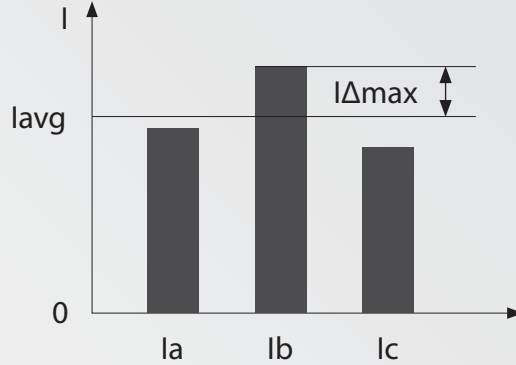

In the equation,  $I_{avg}$  :  $I_a, I_b, I_c$  3 phase average current (RMS).  $I \Delta_{max}$  : maximum difference of each phase and  $I_{avg}$ .

Item		Setting range	Step	Threshold accuracy	Operation accuracy	Protection type
Current unbalance IU	Pickup threshold	20%~80%, and $\geq$ dropout threshold	1%	$\pm 5\%$ (absolute)	$\pm 10\%$	trip / alarm / OFF
	Pickup time delay	1~40s, definite time	1s			
	Dropout threshold	20%~80%, and $\leq$ Pickup threshold	1%			
	Dropout time delay	10~360s, definite time	1s			



### 4.3.2 AIC-H other function

Item		Adjustment range	Step	Threshold accuracy	Operation accuracy	Protection type
Demand current protection ID	Pickup threshold	0.4~1.0In, and ≥ than Dropout threshold	0.1In	±10%		
	Pickup time delay	15~1500s, definite time	15s			
	Dropout threshold	0.4~1.0In, and ≤ than Pickup threshold	0.1In			
	Dropout time delay	15~3000s, definite time	15s			
Under-voltage UV	Pickup threshold	77~828V, and ≤ Dropout threshold	1V	±5%		
	Pickup time delay	1~30s, definite time	0.1s			
	Dropout threshold	77~828V, and ≥ Pickup threshold	1V			
	Dropout time delay	1~100s, definite time	0.1s			
Over-voltage OV	Pickup threshold	77~828V, and ≥ than Dropout threshold	1V	±5%	±10%	
	Pickup time delay	1~5s, definite time	0.1s			
	Dropout threshold	77~828V, and ≤ than Pickup threshold	1V			
	Dropout time delay	1~36s, definite time	0.1s			
Voltage unbalanced UU	Pickup threshold	5%~50%, and ≥ than Dropout threshold	1%	±5% (absolute)		
	Pickup time delay	1~40s, definite time	1s			
	Dropout threshold	5%~50%, and ≤ than Pickup threshold	1%			
	Dropout time delay	10~360s, definite time	1s			
Phase sequence $\Delta \phi$	Pickup threshold	Order(ABC)- reverse(ACB)-OFF		—		Trip / alarm / OFF
	Pickup time delay	0.3s				
	Dropout threshold	Same as Pickup threshold				
	Dropout time delay	3s				
Reverse power RP	Pickup threshold	20~500KW, and ≥ than Dropout threshold	1kW	±10%		
	Pickup time delay	0.2~20s, definite time	0.1s			
	Dropout threshold	20~500KW, and ≤ than Pickup threshold	1kW			
	Dropout time delay	1~360s, definite time	1s			
Over frequency OF	Pickup threshold	45~65Hz, and ≥ than Dropout threshold	0.5Hz	±0.5Hz	±10% / ±30ms	
	Pickup time delay	0.2~5s, definite time	0.1s			
	Dropout threshold	45~65Hz, and ≤ than Pickup threshold	0.5Hz			
	Dropout time delay	1~360s, definite time	1s			
Under frequency UF	Pickup threshold	45~65Hz, and ≤ Dropout threshold	0.5Hz	±0.5Hz		
	Pickup time delay	0.2~5s, definite time	0.1s			
	Dropout threshold	45~65Hz, and ≥ Pickup threshold	0.5Hz			
	Dropout time delay	1~360s, definite time	1s			
Load monitor	Protection type	Method 1 / Method 2		±10%	±10%	Trip / OFF
	Current Setting $I_{c1}/I_{c2}$	$I_{c1} = (0.5 \sim 1) I_{r1}, I_{c1} \geq I_{c2}$	0.1Ir			
ZSI	Ground fault / Short circuit	ON/OFF		±10%	60±30ms	

### ■ Reverse power protection

Reverse power protection is active when sum of 3 phase's active power direction is different from the user setting, and the value is greater than the setting value and time.

### ■ Phase sequence protection

If 2 out of the 3 phase voltage is reverse, the protection will activate. If one phase is gone, the protection will deactivate.

### ■ Load monitor

Method 1	Current	$I_{c1} = (0.5 \sim 1.0) I_r$	Adjust step length: 0.1
	setting	Delay relay closing at $1.05 \sim 1.2 I_{c1}$	
	Operation	0.5Tr protection and the characteristics are the same as overload long time delay protection.	
	characteristics	$I_{c2} = (0.5 \sim 1.0) I_r, \leq I_{c1}$	Adjust step length: 0.1
	Time delay	Delay relay closing at $1.05 \sim 1.2 I_{c2}$	
	Current setting	0.25Tr protection and the characteristics are the same as those of overloading and long-delay.	
Method 2	Operation	$I_{c1} = (0.5 \sim 1.0) I_r$	Adjust step length: 0.1
	characteristics	Delay relay closing at $1.05 \sim 1.2 I_{c1}$	
	Time delay	0.5Tr protection and the characteristics are the same as overload long time delay.	
	Current	$I_{c2} = (0.5 \sim 1.0) I_r, \leq I_{c1}$	Adjust step length: 0.1
	setting	$< I_{c2}$ , delay relay closing	
	Operation	60s	

The controller can program the output of two passive signal contacts for load monitor. The output signal contacts can be used for monitoring alerts, controlling the load of tripping sub-circuit and ensuring a normal power supply for the main system. There are two types of load monitor methods available (the user can choose one of them).

- Method 1: It can be used to control two sub-circuit loads. When the working current exceeds  $1.2I_{c1}$  or  $1.2I_{c2}$ , controller will delay the output of signal contacts according to inverse time characteristics. The characteristic curve of inverse time and the characteristic curve of overload long-time delay are the same, but the setting current value can be set independently.
- Method 2: It is generally used to control sub-circuit loads. When the working current exceeds  $1.2I_{c1}$ , the controller will output signal contact point break sub-circuit load according to inverse time characteristics. The characteristic curve of inverse time and the characteristic curve of overload long-time delay are the same, but the setting value has to be  $I_{c1}I_{c2}$ . If after tripping the sub-circuit load, the current will return to normal. When the current is lower than  $I_{c2}$  for 60s continuously, the controller will output another signal contact to pick up the broken load and restore the power supply of system.

■ ZSI (Zone selective Interlocking)

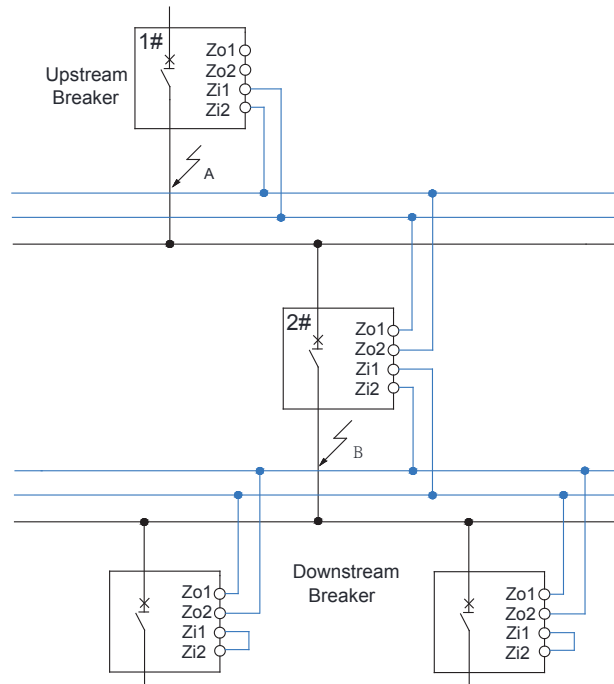

Zone-selective interlocking (ZSI) has multiple classified protection system which is designed to minimize the faulty impact on whole electrical distribution system by reducing the time it takes to clear the fault and maintaining system coordination. This function is suit with short circuit and ground fault protection ( $I^2t$  is set to off)

Example :

1. Occurrence of Fault A: The upstream breaker (1#) received no signal from downstream breaker and performs instantaneous trip operation to protect system.
2. Occurrence of Fault B: Breaker (2#) will send ZSI signal to upstream breaker (1#) and breaker (1#) will obey their delay setting to maintain coordination in other areas of the system. Breaker (2#) received no ZSI signal from downstream breaker and performs instantaneous trip operation.

Connection and limits:

Use twisted pair or shielded cable, 14AWG-2.5mm<sup>2</sup>/22AWG-0.4mm<sup>2</sup>, maximum length of 300m.

Maximum of 15 downstream equipment can be connect to input of ZSI ( Zi1-Zi2 )

Maximum of 15 upstream equipment can be connect to output of ZSI ( Zo1-Zo2 ) .

Note: 1. The terminals breaker's Zi1 and Zi2 should be shorted, if its open, ZSI will trip when short-circuit and ground fault occurred.

2. Upper breaker's I<sub>sd</sub> or I<sub>g</sub> cannot set to 0s, or ZSI may not be working properly.

## 4.3.3 Display Measurement Parameter

Item		Adjust range	Accuracy	Note
Current	Phase current Ia、Ib、Ic	0.2~2In	±3%	AIC-E AIC-A AIC-H
	N phase current IN			
	Ground Ig	0.2~1In	±5%	
	Earth leakage If	0.5~30A	±5%	
	Current unbalance	0%~200%	±5% (absolute)	AIC-A AIC-H
Voltage	Line voltage Uab、Ubc、Uca	45~900V	±2.5%/±2V	AIC-H
	Phase voltage Uan、Ubn、Ucn	26~528V		
	Voltage unbalanced	0%~200% (line voltage)	±5% (absolute)	
Power	Active power P (W)	-30~30MW	±10%	
	Reactive power Q (Var)			
	Apparent power S (VA)			
	Power factor PF	-1~+1		
Demand current	Phase current Ia、Ib、Ic	0.2~2In	±3%	
	N phase current IN			
	Time window	Window 5~60min	Step 1min	
Demand power	Active power P	-30~30MW	±10%	
	Reactive power Q			
	Apparent power S			
	Time window	Window 5~60min	Step 1min	
Energy	Total energy E.P (kWh)	-2000G~+2000G	±10%	
	Total energy E.Q (kVarh)			
	Total energy E.S (kVAh)	0~4000G		
	Input energy E.P (kWh)	-2000G~+2000G		
	Input energy E.Q (kVarh)			
	Output energy E.P (kWh)			
	Output energy E.Q (kVarh)			
Frequency	F (A phase voltage frequency)	45~65Hz	±0.1Hz	
Harmonic	Fundamental wave – Current I	0.2~2In	±3%	
	Fundamental wave– Voltage U	Line voltage 45~900V	±3%/±2V	
		Phase voltage 26~528V		
	THD、thd-current I	0~1000%	±5%	
	THD、thd- voltage U			
	FFT-current I	0~1000%	±5%	
	FFT-voltage U			
Harmonic analysis	1~31harmonic analysis			

■ **System type**

- 3Φ3W3CT : 3 phase 3 wire 3 pole without neutral line, measure line voltage, phase current.
- 3Φ4W3CT : 3 phase 4 wire 3 pole without neutral line, measure line & phase voltage, phase current.
- 3Φ4W4CT : 3 phase 4 wire 4 pole (4P or 3P+N) with neutral line, measure line & phase voltage, phase current.

■ **Voltage measuring**

- 3 phase 4 wire, voltage N phase must be connected (secondary circuit terminal 21#).
- 3 phase 3 wire, voltage N phase (21#) and B phase (23#) must shorted.

■ **Demand measurements**

Required value : Average of current, power with in a time window for each phase.  
 Set the time window in measurement parameter (5~60min). If the setting had been change, the value will automatic be recalculated.

■ **Power Sign**

- P+ : Forward measurement, corresponds to the usual flow, meaning from top to bottom
- P- : Reverse measurement.

■ **Power Diagram**

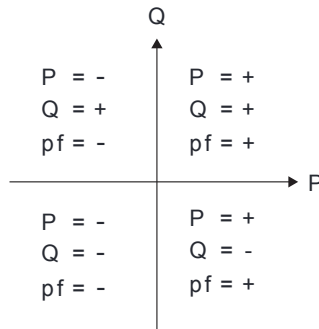

■ **Energy measurement**

- Total energy: all of the energy.
- Input energy: energy consumption, positive increase.
- Output energy: energy release, reverse increase.
- Energy measurement vales can be reset.

■ **Harmonic measurement**

- Fundamental wave: measure fundamental wave current, line voltage, phase voltage.
- Distortion rate: Total harmonics distortion (THD) rate to fundamental wave.  
 Total harmonics distortion (THD) rate to valid values.
- FFT amplitude: display 3~31 times of FFT amplitude of each odd harmonic, use rectangular display to show different frequency harmonic amplitude, achieving harmonic spectrum analysis.
- Waveform: Capture current, voltage waveforms in one cycle with real-time updates.

#### 4.3.4 Other functions

##### ■ Self-diagnosed functions

When the working environment of the controller exceeds 70°C or when 60% of the contact has been worn off or when the circuit breaker cannot be tripped, the user would be notified by controller and relevant parameters will meanwhile be recorded.

##### ■ Trip/Alarm / Self-diagnosed records

Record up to 10 events records during faulted, including date, fault status and data.

Tripping fault type: overcurrent, ground fault / leakage (optional), current unbalance, voltage protection, frequency protection reserves power.

Alarm fault type: ground fault / leakage (optional), current unbalance, voltage protection, frequency protection reserves power.

Self-diagnosed fault type: over-temperature, contacts worn, breaker refused to trip.

##### ■ Position change record

Every switch of mode is count as a position change, and the record detail is as listed:

Position Change date (year, month, day, hour, minute, second).

Position Change type (Open / close / trip).

Position Change reason (Manual / remote / fault / test).

Position Change record can show up to 10 times of recent switching record.

##### ■ Operation counter

The total number of operating cycles will be registered and the data cannot be manually cleared.

##### ■ Contact wearing rate

The controller will simulate and calculate the circuit breaker's main contact wearing rate according to information such as the fault current at tripping. The contact value of the controller from the factory is 100%, indicating no wearing of the contact point. The contact will be worn by a certain level due to every fault induced tripping. If the value obtained from subtracting the corresponding amount of wearing from the current contact value is less than 40%, the system will send out a self-diagnosed fault alert signal. After changing the main contact of the circuit breaker, the user can reset the initial wear rate to 100% through the human-machine interface or remote communication.

##### ■ Test function

The controller will simulation an instantaneous trip test, causing the breaker to trip. It is use for breaker's on-site debugging, regular maintenance and trouble shooting. The red reset button must be press before closing the breaker every time, cannot be press during normal operation.

##### ■ System clock

The system clock function is for recording the time and date during faults.

### ■ Programmable contact function

Controller has 2 sets of independent contact signal output; the function can be defined by controller interface or remote compunction. Contacts function is listed below.

Code	Contact type	Contact output	Contact cleared
1	N/A	N/A	N/A
2	Pre-alarm	Pre-overload alarm	Pre-overload cleared
3	Overload	Overload long time delay trip	Closing after fault is cleared
4	Short circuit	Short circuit short time delay trip	1. Closing after fault is cleared 2. Function disable
5	Instantaneous	Instantaneous trip	1. Closing after fault is cleared 2. Function disable
6	MCR	MCR fault trip	1. Closing after fault is cleared 2. Instantaneous function enable
7	Monitor 1	Load monitor $I_{c1}$ uninstal	1. Load 1 abnormal cleared 2. Function disable
8	Monitor 2	Load monitor $I_{c2}$ uninstal (method 1) or overload (method 2)	1. Load 2 abnormal cleared 2. Function disable
9	Ground / leakage	Ground / leakage alarm	1. Closing after fault is cleared 2. Function disable
10	Unbalance (Iunbal)	Current unbalance tripping alarm	
11	Unbalance (Uunbal)	Voltage unbalance tripping alarm	
12	Over voltage	Over voltage tripping alarm	
13	Under voltage	Under voltage tripping alarm	
14	Over frequency	Over frequency tripping alarm	
15	Under frequency	Under frequency tripping alarm	
16	Demand value	Demand current value tripping alarm	
17	Reversed power	Reversed power tripping alarm	
18	Phase sequence	Phase sequence tripping alarm	
19	Trip	Fault tripping status	Closing after fault is cleared
20	Open	Breaker in open mode	Close the breaker
21	Close	Breaker in close mode	Open the breaker
22	Refused action	Tripping failed, breaker refused to move	Open the breaker
23	Over temperature	Over temperature alarm	Alarm cleared
24	Contact wear	Contact serious wearing alarm	Reset contact wearing rate
25	Remote open	Remote open	Contact continue 200ms
26	Remote close	Remote close	Contact continue 200ms

Note: 1. Contact is normal open, input is normal close (except load monitor  $I_{c2}$  method 2)

2. Non-closure contact: contact will remain operation before eliminating fault alarm.

**■ Communication (AIC-HC optional)**

Achieve remote control, communication, metering and setting with RS-485 / Modbus-RTU support.

"Local" mode: controller will not respond to remote control, such as parameter modification or remote closing / opening.

"Remote" mode: Controller will respond to remote control, manual modification will not affect.

Cable: RS485Shielded twisted pair

Baud rate: 4800 / 9600 / 19200 / 38400bps adaptive.

**■ Parameter lock**

"Unlock" mode: parameter can be modify.

"Lock" mode: parameter cannot be modify.



## 5. Characteristic Curves

### 5.1 Overload (EIT) 、 Short-circuit 、 Instantaneous protection

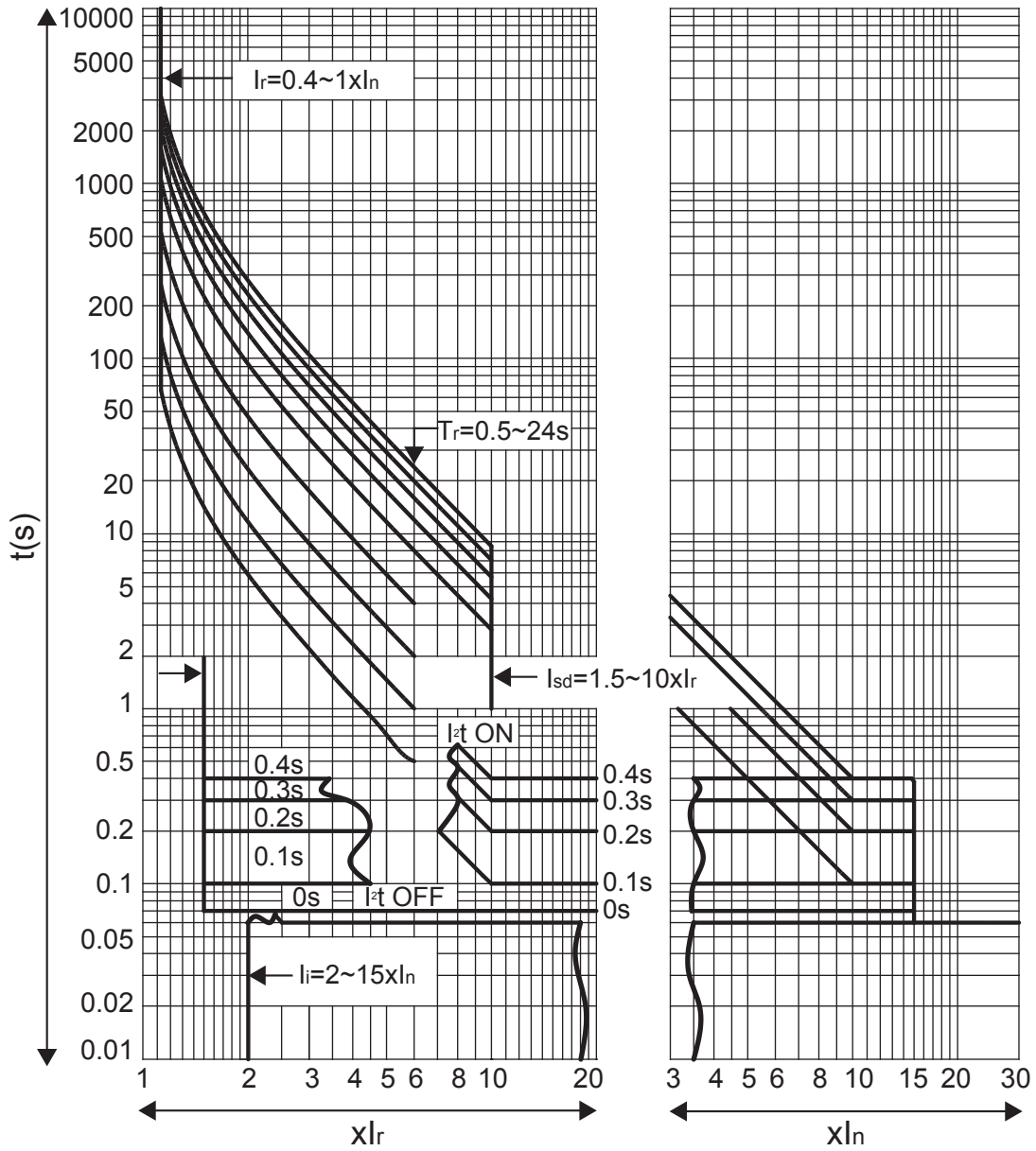

### 5.2 Five Tripping Curves (EIT、SIT、VIT、DT、HVF)

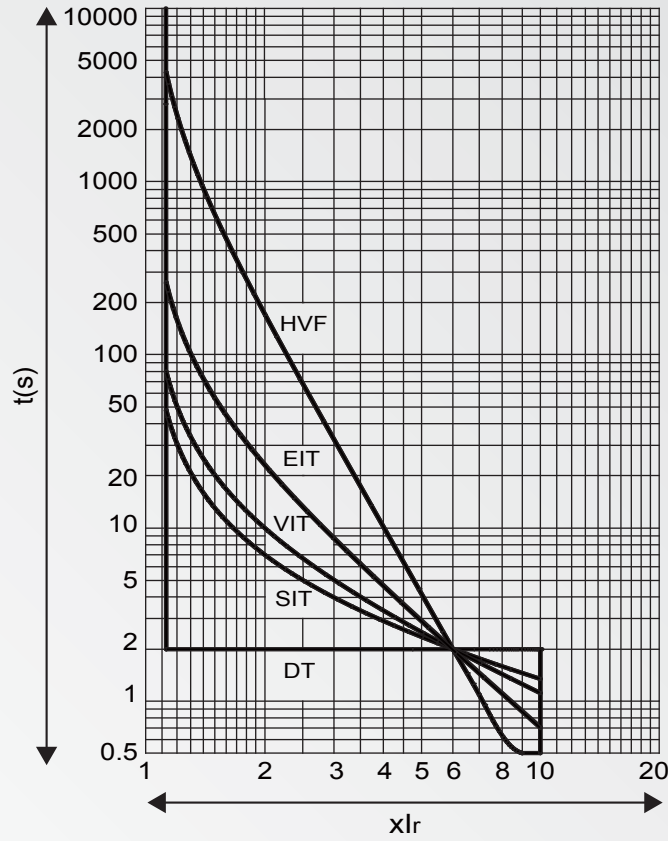

### 5.3 Ground fault protection

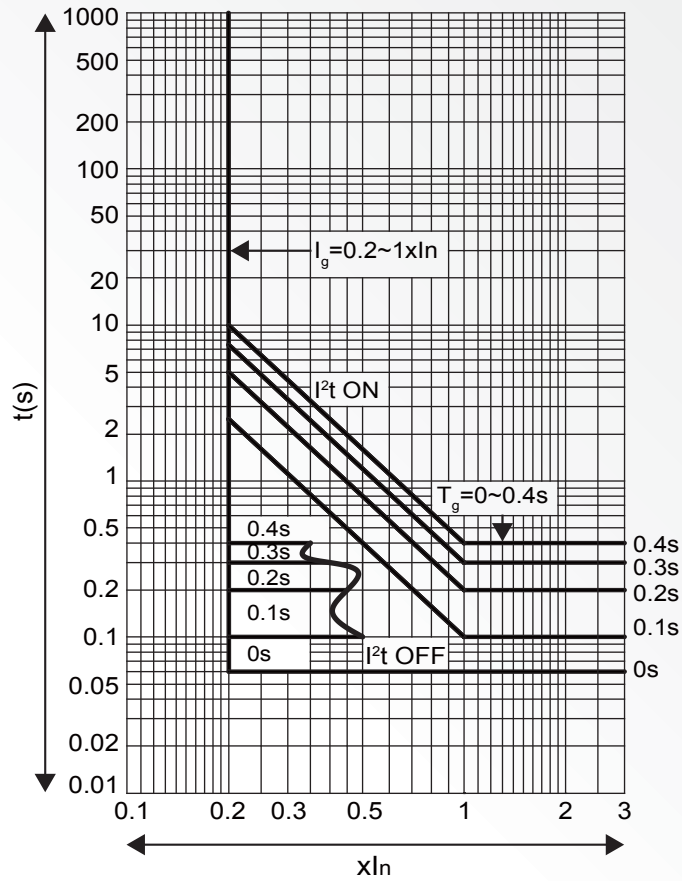

5.4 Leakage protection

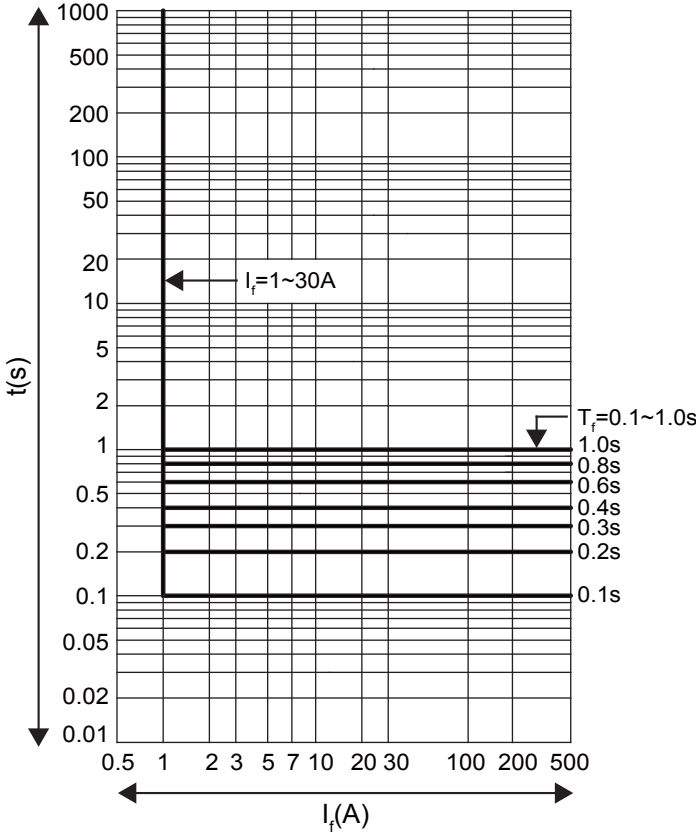

## 6. Intelligent Controller Usage

### 6.1 Panel Schematic Diagram

AIC controller has E and A type, schematic diagram is shown.

**E type controller** can be defined by 3 zones:

LED operation light zone, knob tuning zone, operation status zone.

■ **LED operation light zone:**

Overload protection light Ir, short circuit protection light Isd, instantaneous protection light li, ground fault protection light Ig.

■ **Knob tuning zone: parameter for overload, short circuit, ground fault.**

Overload protection	Current setting Ir	Iu=0.4~0.95In (12 values, step 0.05In) Ir=0~0.05In+Iu (11 values, step 0.005In)
	Time setting Tr	0.5-1-2-4-8-12-16-20-24s (@6Ir)
Short circuit protection	Current setting Isd	1.5-2-3-4-5-6-8-10Ir-OFF
	Time setting Tsd	I <sup>2</sup> t ON : 0.1-0.2-0.3-0.4s (@10Ir) I <sup>2</sup> t OFF : 0-0.1-0.2-0.3-0.4s
Instantaneous protection	Current setting li	2-4-6-8-10-11-12-15In-OFF
Ground fault protection	Current setting Ig ≥80A	0.2-0.3-0.4-0.5-0.6-0.7-0.8-1In-OFF
	Time setting Tg	I <sup>2</sup> t ON : 0.1-0.2-0.3-0.4s (@1.0In) I <sup>2</sup> t OFF : 0-0.1-0.2-0.3-0.4s

E Type



■ **Operation status zone: Run green light, Overload pre-alarmed light, alarm light.**

Status		LED							
		Run (green)	Overload pre-alarm (red)	Alarm	Ir	Isd	li	Ig	
Open	Overload protection trip		-	-	light	light	-	-	-
	Short circuit protection trip		-	-	light	-	light	-	-
	MCR protection trip		-	-	light	-	-	light	-
	Instantaneous protection trip		-	-	light	-	-	light	-
	Ground fault protection trip		-	-	light	-	-	-	light
Close	Normal		light	-	-	-	-	-	-
	Abnormal power grid	Not refuse action	Pre overload	-	blink	-	-	-	-
			Overload protection	-	light	-	-	-	-
			Short circuit protection	-	light	-	-	-	-
			Ground fault protection	-	-	blink	-	-	-
	Abnormal power grid	Refuse action	Overload protection	-	-	blink	light	-	-
			Short circuit protection	-	-	blink	-	light	-
			MCR protection	-	-	blink	-	-	light
			Instantaneous protection	-	-	blink	-	-	light
			Ground fault protection	-	-	blink	-	-	-
Over temperature			-	-	blink	-	-	blink	-

A/H controller can be defined by 4 zones:  
LCD display zone, button control zone, knob tuning zone, operation status zone.

■ **LCD display zone:**

128\*64 dot matrix display, display power grid parameter (current, voltage, etc), protection parameter, records. Come with English or Chinese language.

■ **Button control zone: include "Esc", "↑", "↓", "↵" buttons.**

- "Esc" : return button
- "↑" : page up or increase value button
- "↓" : page down or decrease value button
- "↵" : confirm button

■ **Operation status zone: Run green light, Overload pre-alarm red light, alarm light.**

■ **Knob tuning zone: parameter for overload, short circuit, ground fault.**

Overload protection	Current setting $I_r$	$I_u=0.4\sim0.95I_n$ (12 values, step $0.05I_n$ ) $I_r=0\sim0.05I_n+I_u$ (11 values, step $0.005I_n$ )
	Time setting $T_r$	0.5-1-2-4-8-12-16-20-24s (@ $6I_r$ )
Short circuit protection	Current setting $I_{sd}$	1.5-2-3-4-5-6-8-10 $I_r$ -OFF
	Time setting $T_{sd}$	$I^2t$ ON : 0.1-0.2-0.3-0.4s (@ $10I_r$ ) $I^2t$ OFF : 0-0.1-0.2-0.3-0.4s
Instantaneous protection	Current setting $I_i$	2-4-6-8-10-11-12-15 $I_n$ -OFF
Ground fault protection	Current setting $I_g \geq 80A$	0.2-0.3-0.4-0.5-0.6-0.7-0.8-1 $I_n$ -OFF
	Time setting $T_g$	$I^2t$ ON : 0.1-0.2-0.3-0.4s (@ $1.0I_n$ ) $I^2t$ OFF : 0-0.1-0.2-0.3-0.4s
Earth leakage protection	Current setting $I_f$	1-2-3-5-7-10-20-30A-OFF
	Time setting $T_f$	Trip : 0.1-0.2-0.4-0.8s Alarm : 0.1-0.2-0.4-0.8-1s

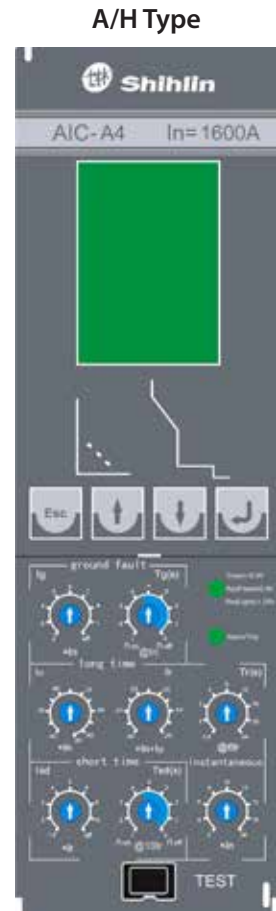

## 6.2 Page Description

### 6.2.1 Measurement Page

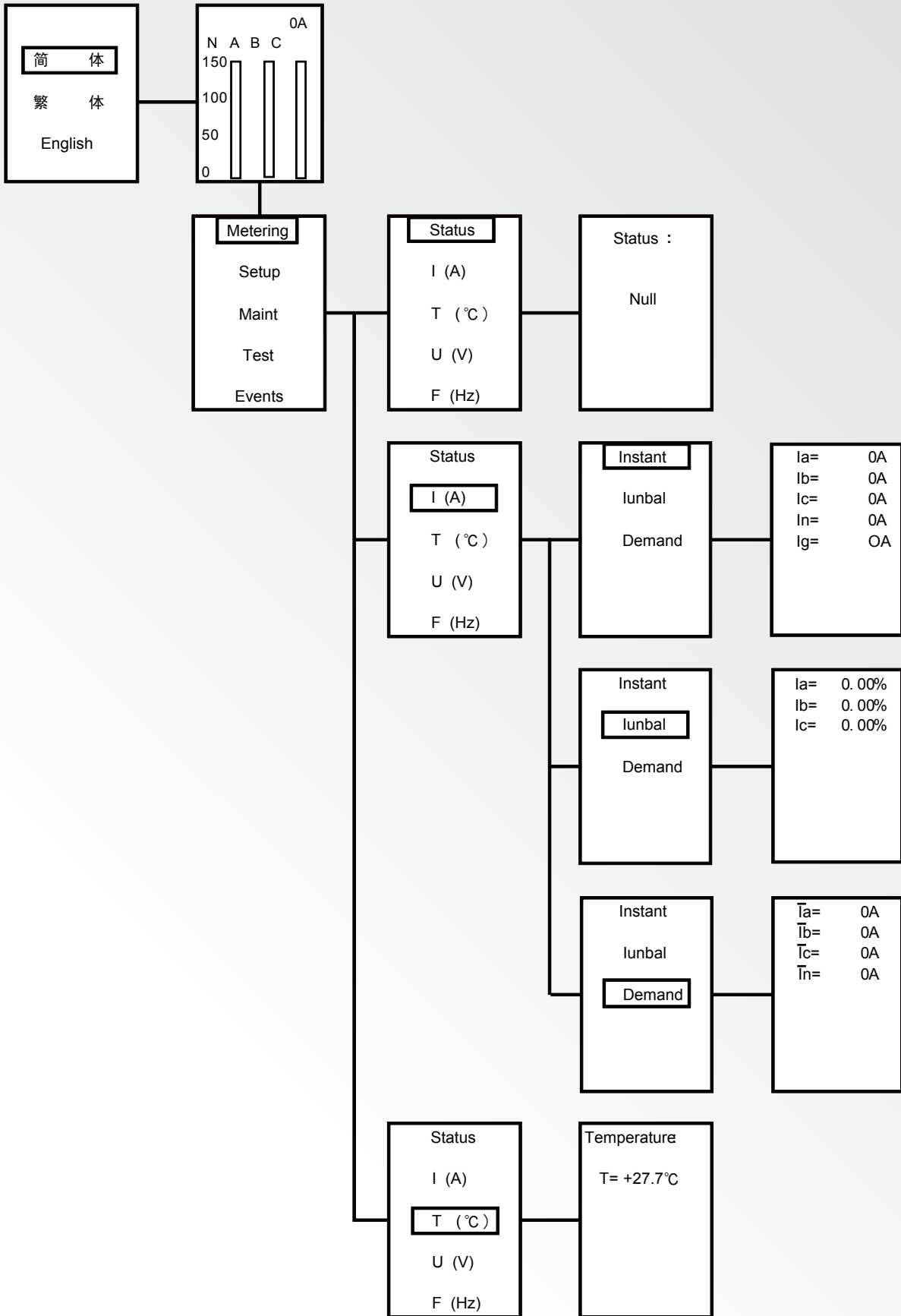

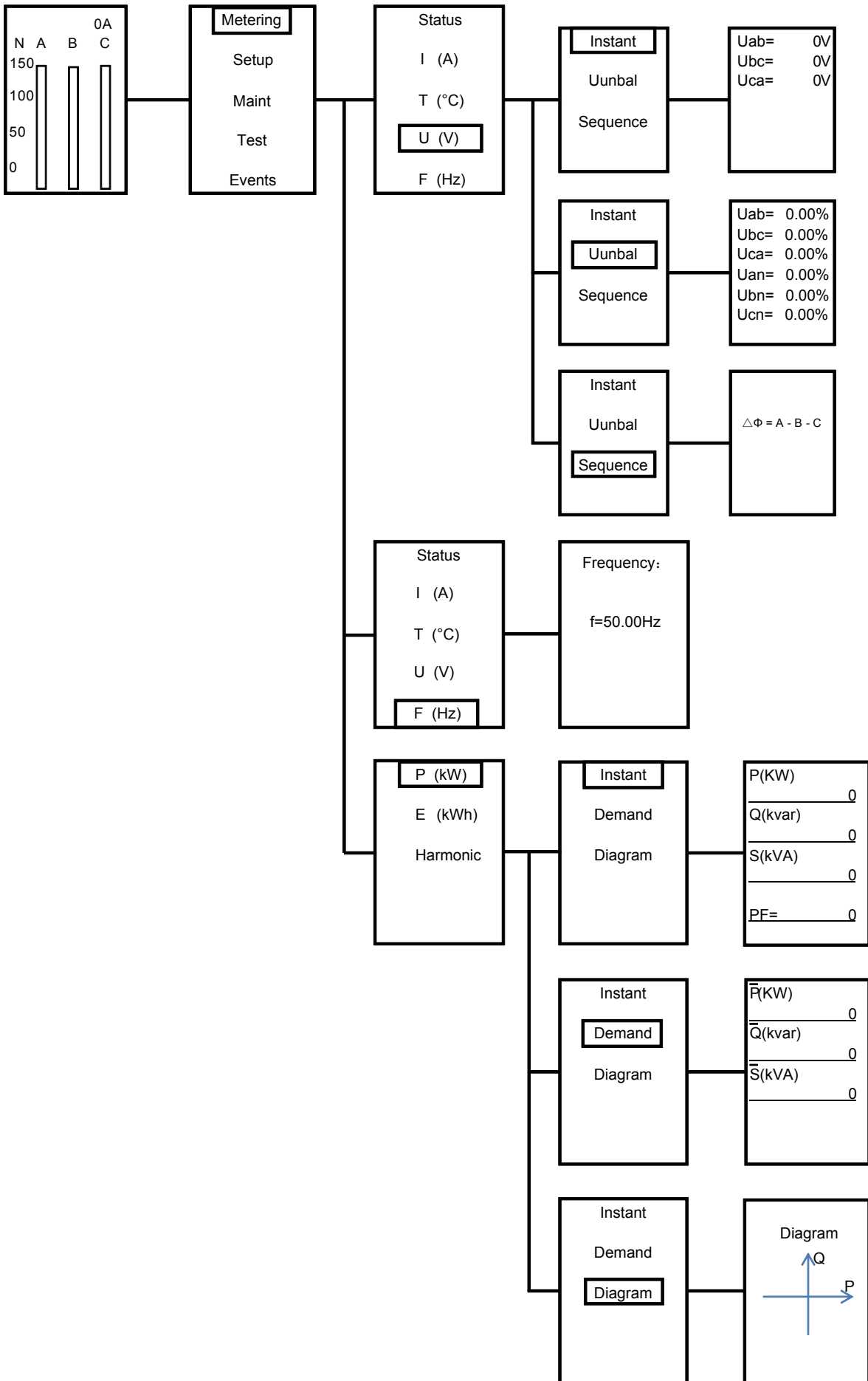

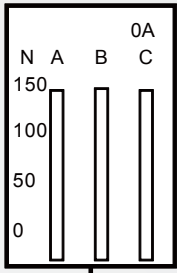

**Metering**

Setup

Maint

Test

Events

P (kW)

**E (kWh)**

Harmonic

**E.Total**

E.In

E.Out

E.Reset

E.Total

E.P(kwh) 0

E.Q(kvarh) 0

E.S(kVAh) 0

E.Total

**E.In**

E.Out

E.Reset

E.In

E.P(kwh) 0

E.Q(kvarh) 0

E.Total

E.In

**E.Out**

E.Reset

E.Out

E.P(kwh) 0

E.Q(kvarh) 0

E.Total

E.In

E.Out

**E.Reset**

**Yes**

No

P (kW)

E (kWh)

**Harmonic**

**Fundament**

Distortion

FFT

Waveform

Fundament

**I (A)**

U (V)

Fundament

Ia= 0A

Ib= 0A

Ic= 0A

In= 0A



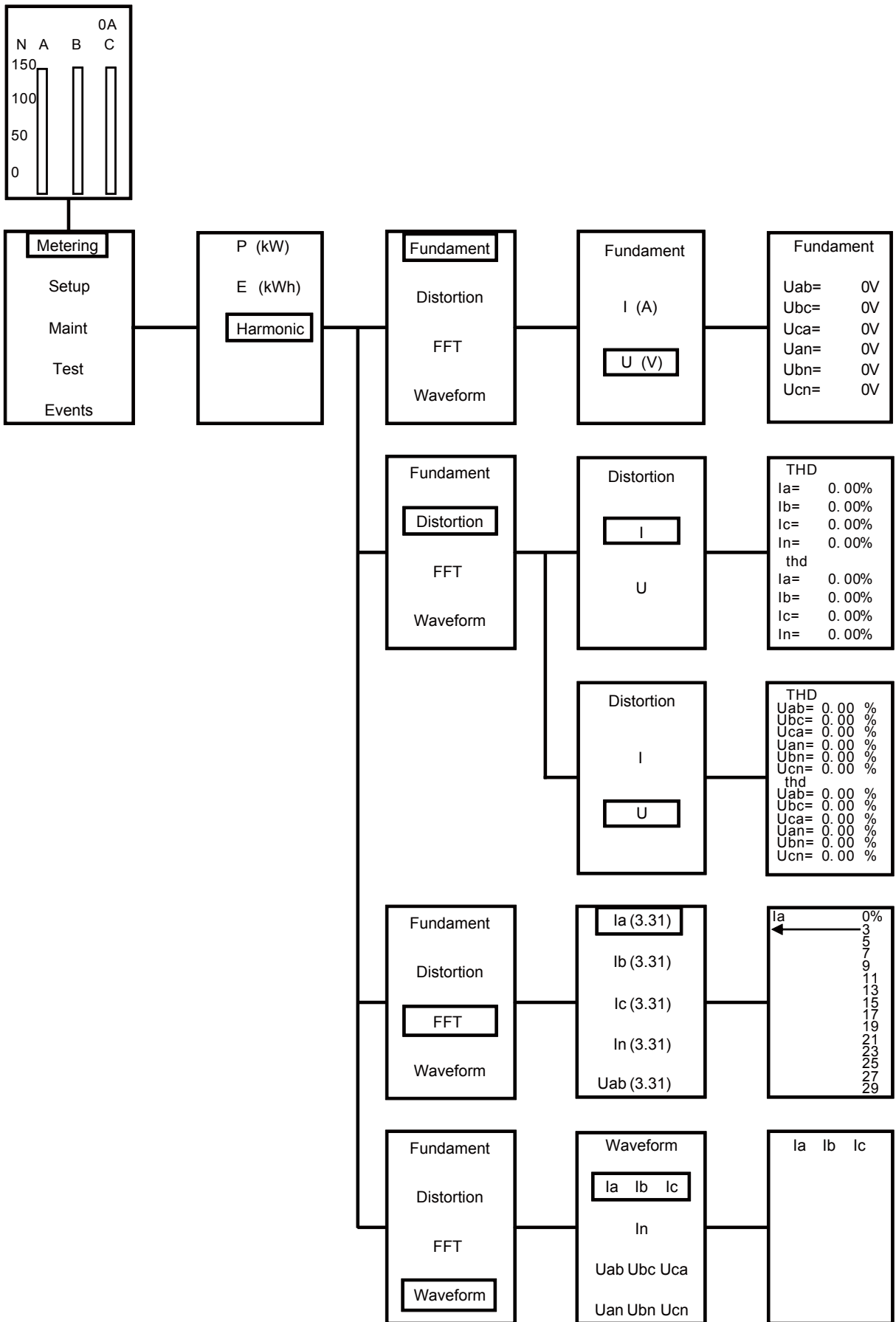

6.2.2 Parameter page

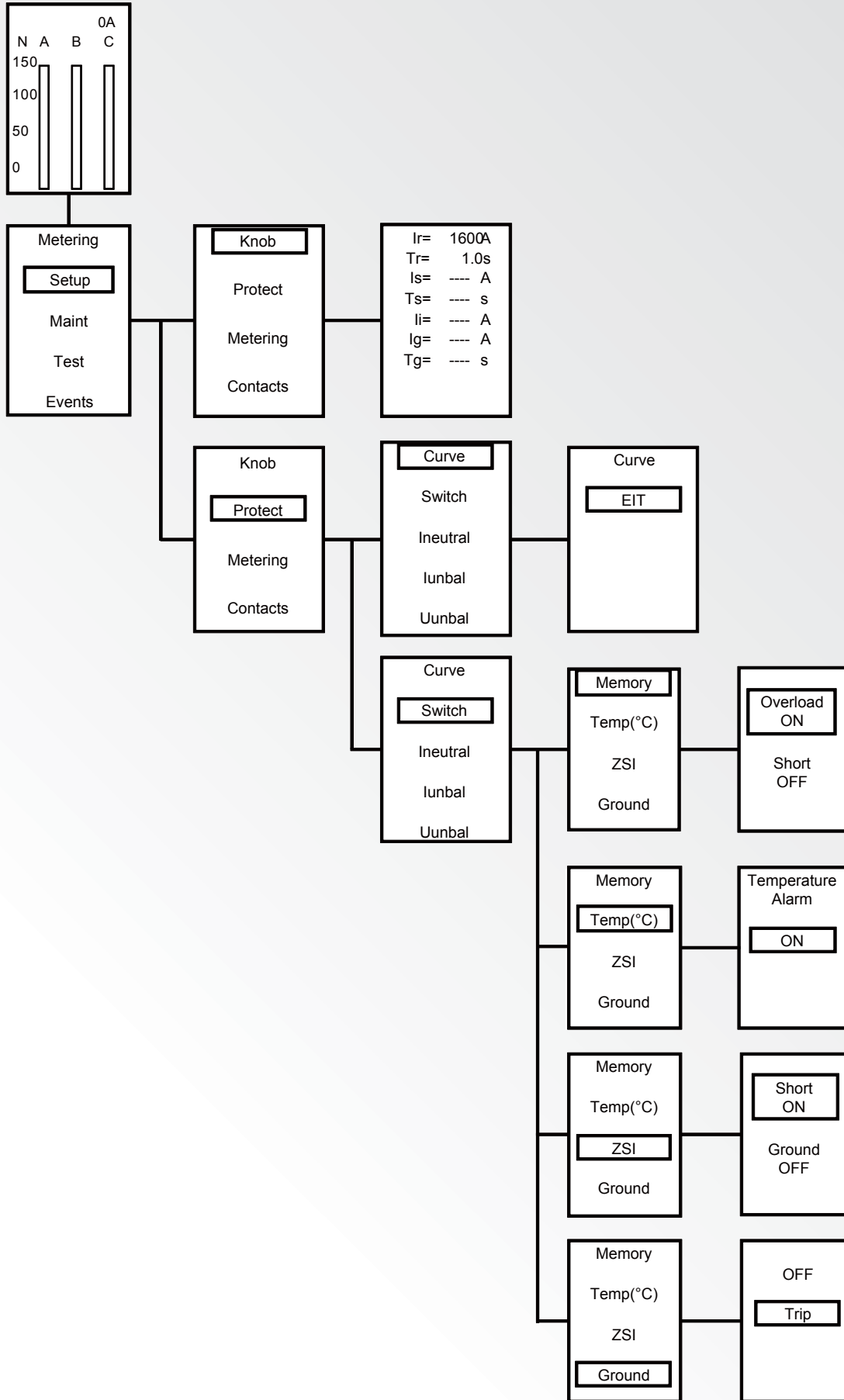

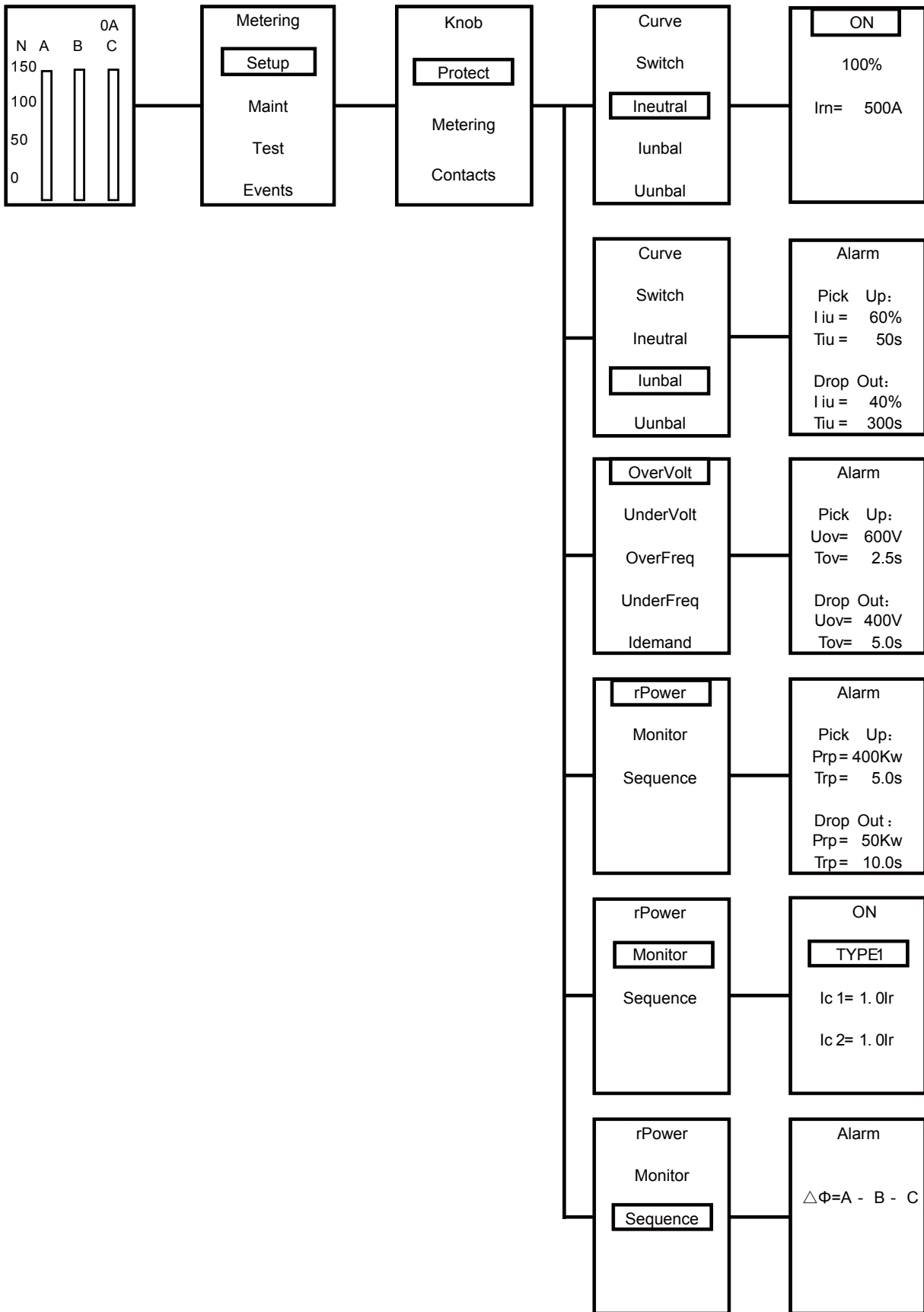

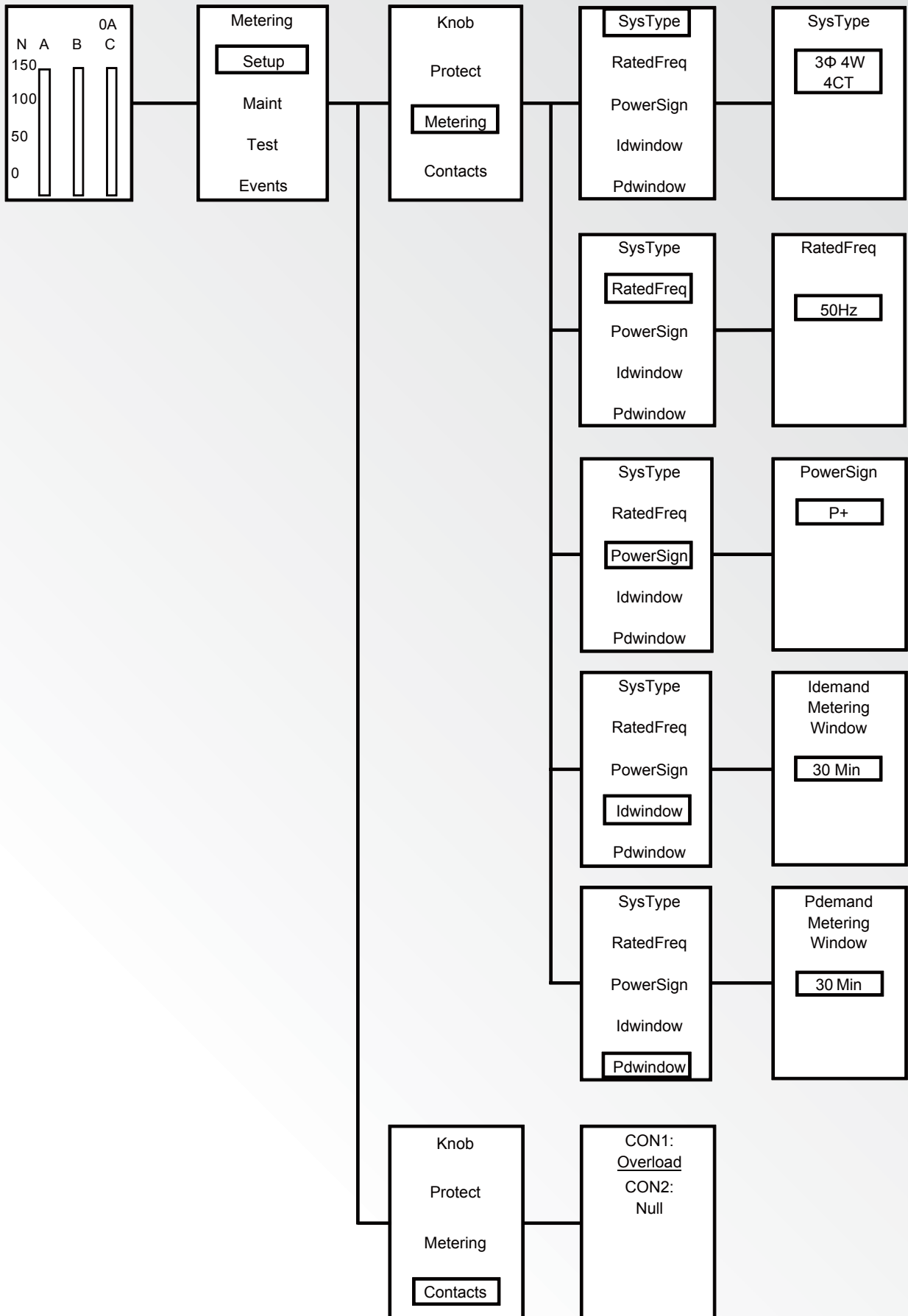

### 6.2.3 Maintenance page

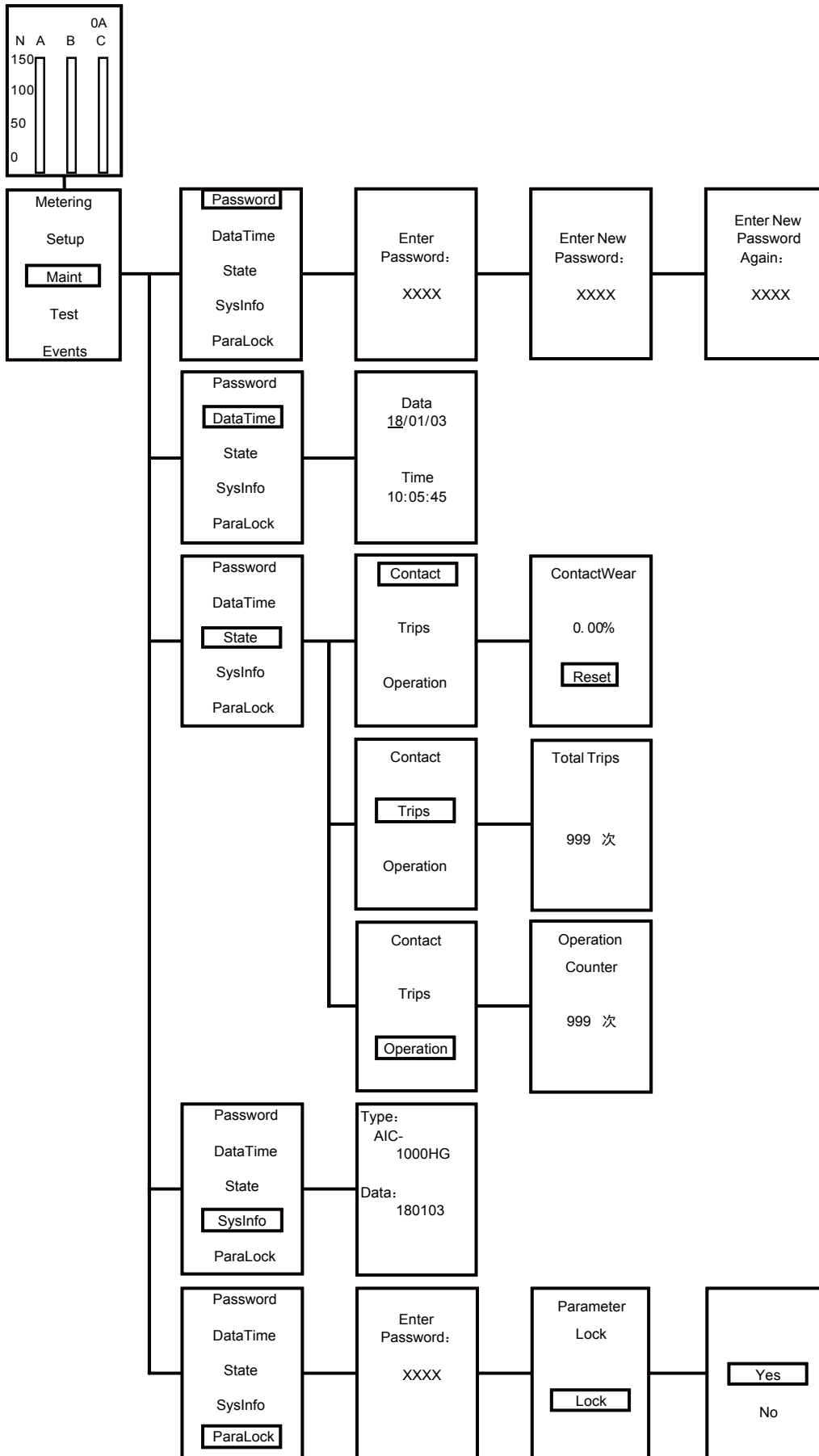

6.2.4 Testing page

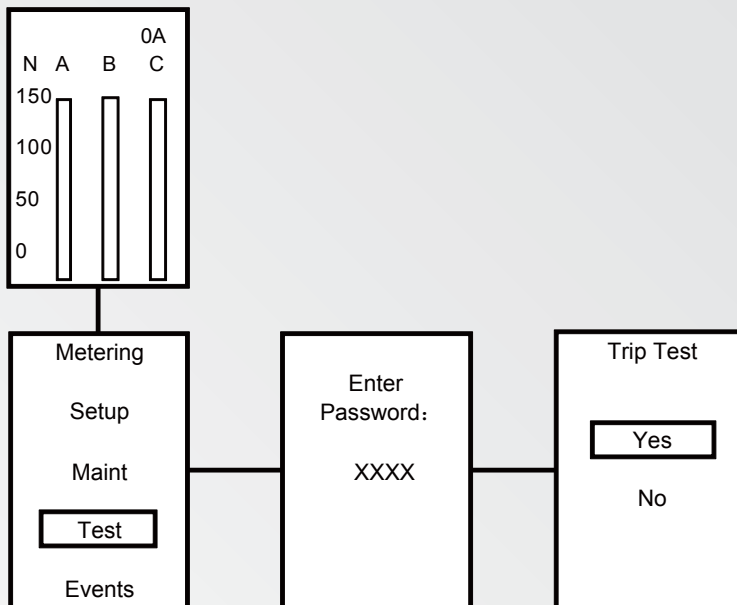

6.2.5 Language, communication page

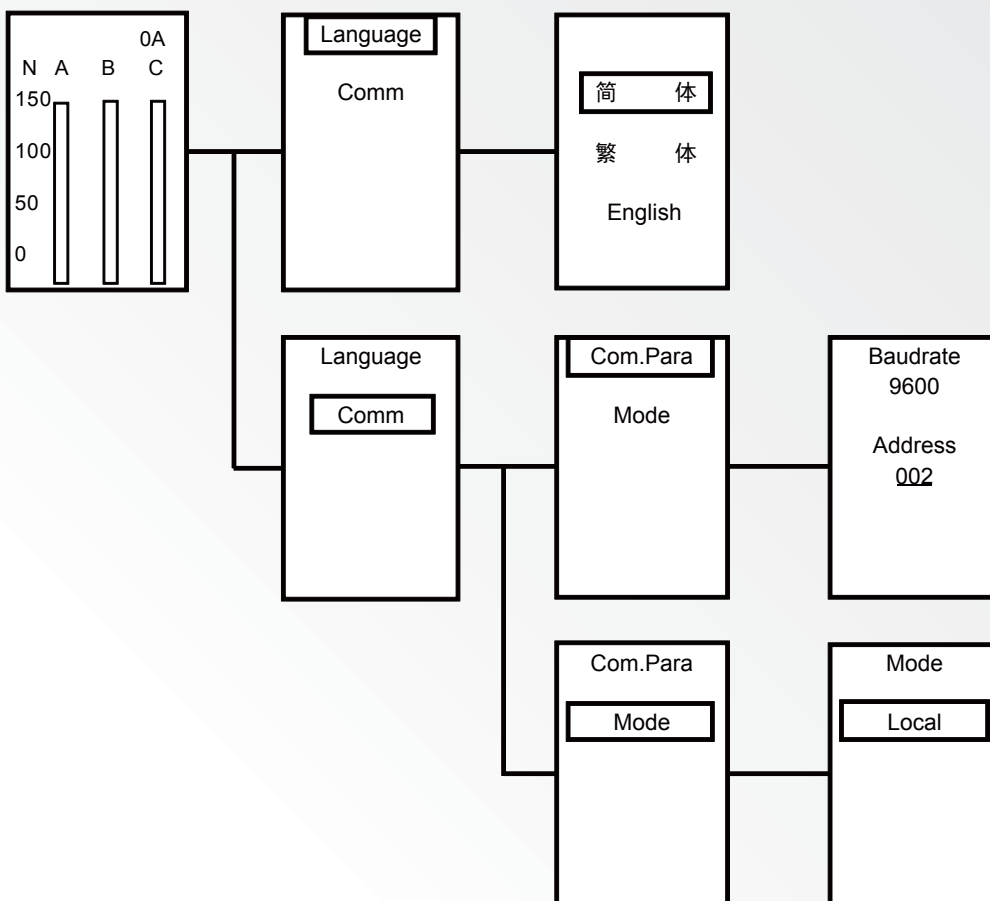

6.2.6 Record page

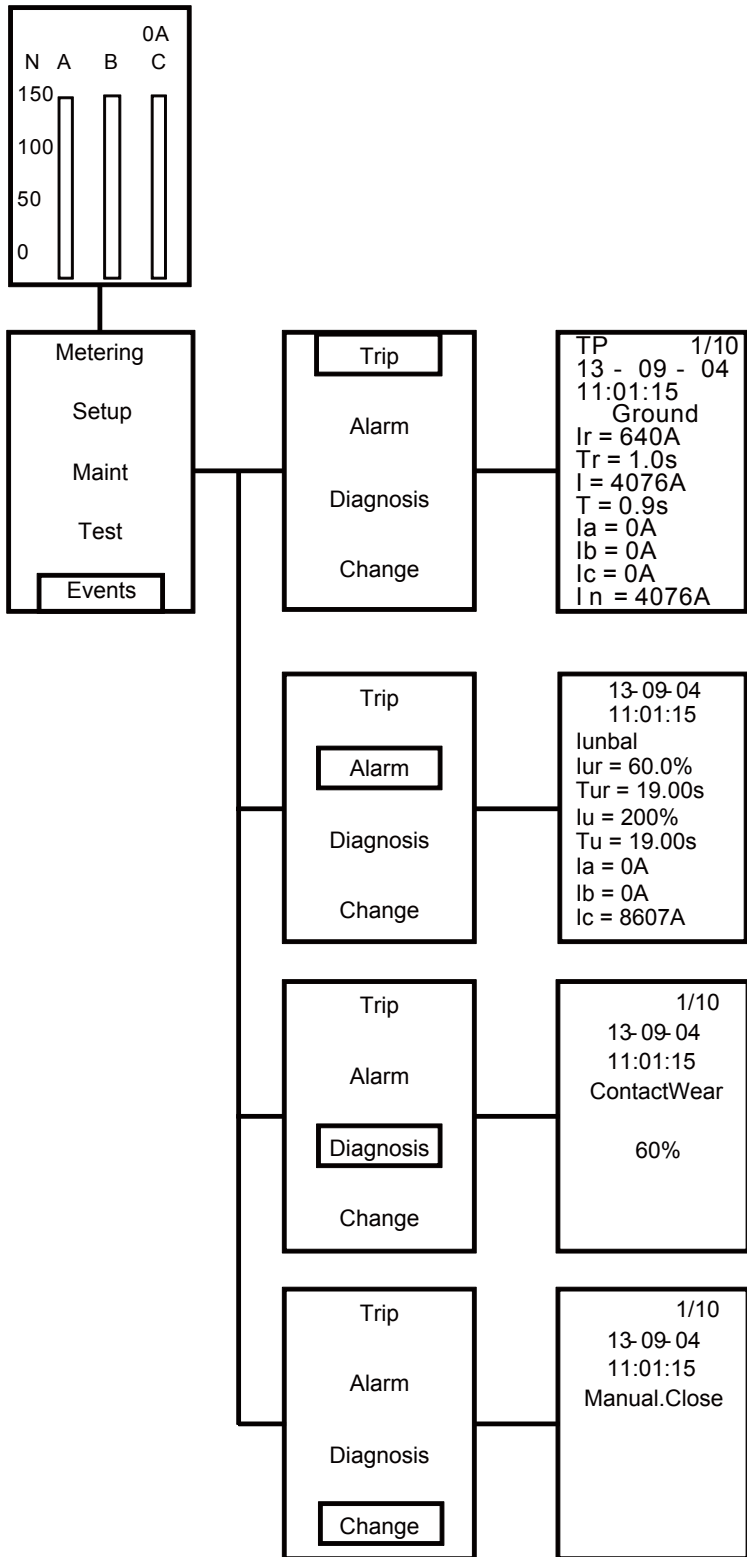

## 6.3 Factory setting

Item		Adjust range	Factory setting
Overload protection	Curve	EIT / DT / SIT / VIT / HVF	EIT
	Current setting $I_r$	0.4~1In	1In
	Time setting $T_r$	Standard : 0.5~24s HVF : 0.5~4s	Standard : 24s HVF : 4s
Short circuit protection	Current setting $I_{sd}$	1.5~10I <sub>r</sub>	4I <sub>r</sub>
	Time setting $T_{sd}$	Inverse time $I^2T$ on : 0.1~0.4s Definite time $I^2T$ off : 0~0.4s	Inverse time 0.4s
Instantaneous protection	Current setting $I_i$	2~15In	15In
Ground fault protection	Current setting $I_g$	0.2~1In	1In
	Time setting $T_g$	Inverse time $I^2T$ on : 0.1~0.4s Definite time $I^2T$ off : 0~0.4s	Inverse time 0.4s
Leakage protection	Current setting $I_f$	1~30A	30A
	Time setting $T_f$	Trip : $T_f=0.1\sim0.8s$ Alarm : $T_f=0.1\sim1s$ , Definite time	Trip 0.8s
Function	Ground fault	Trip / Alarm	Trip
	Thermal memory	Overload: On / Off	On
		Short circuit: On / Off	
	ZSI	Short circuit: On / Off	Off
Ground fault: On / Off			
Temperature alarm	On / Off	On	
Neutral protection	Protection	On / Off	3P : Off 4P : On
	Setting	50% / 100%	100%
Current unbalance IU	Protection	Off / Trip / Alarm	Off
	Pickup threshold	20%~80%, and $\geq$ Dropout threshold	80%
	Pickup time delay	1~40s, Definite time	40s
	Dropout threshold	20%~80%, and $\leq$ Pickup threshold	20%
	Dropout time delay	10~360s, Definite time	10s
Demand current protection ID	Protection	Off / Trip / Alarm	Off
	Pickup threshold	0.4~1In, and $\geq$ Dropout threshold	1In
	Pickup time delay	15~1500s, Definite time	1500s
	Dropout threshold	0.4~1.0In, and $\leq$ Pickup threshold	0.4In
	Dropout time delay	15~3000s, Definite time	15s
Voltage unbalanced UU	Protection	Off / Trip / Alarm	Off
	Pickup threshold	5%~50%, and $\geq$ Dropout threshold	50%
	Pickup time delay	1~40s, Definite time	40s
	Dropout threshold	5%~50%, and $\leq$ Pickup threshold	10%
	Dropout time delay	10~360s, Definite time	10s
Under-voltage UV	Protection	Off / Trip / Alarm	Off
	Pickup threshold	77~828V, and $\leq$ Dropout threshold	77V
	Pickup time delay	1~30s, Definite time	30s
	Dropout threshold	77~828V, and $\geq$ Pickup threshold	100V
	Dropout time delay	1~100s, Definite time	10s



Item		Adjust range	Factory setting
Over-voltage OV	Protection	Off / Trip / Alarm	Off
	Pickup threshold	77~828V, and $\geq$ Dropout threshold	725V
	Pickup time delay	1~5s, Definite time	5s
	Dropout threshold	77~828V, and $\leq$ Pickup threshold	704V
	Dropout time delay	1~36s, Definite time	10s
Phase sequence $\Delta \Phi$	Protection	Off / Trip / Alarm	Off
	Setting	Sequence (ABC) / Reverse (ACB)	ABC
Over frequency OF	Protection	Off / Trip / Alarm	Off
	Pickup threshold	45~65Hz, and $\geq$ Dropout threshold	65Hz
	Pickup time delay	0.2~5s, Definite time	5s
	Dropout threshold	45~65Hz, and $\leq$ Pickup threshold	60Hz
	Dropout time delay	1~360s, Definite time	1s
Under frequency UF	Protection	Off / Trip / Alarm	Off
	Pickup threshold	45~65Hz, and $\leq$ Dropout threshold	45Hz
	Pickup time delay	0.2~5s, Definite time	5s
	Dropout threshold	45~65Hz, and $\geq$ Pickup threshold	50Hz
	Dropout time delay	1~360s, Definite time	1s
Reverse power RP	Protection	Off / Trip / Alarm	Off
	Pickup threshold	20~500KW, and $\geq$ Dropout threshold	500kw
	Pickup time delay	0.2~20s, Definite time	20s
	Dropout threshold	20~500KW, and $\leq$ Pickup threshold	100kw
	Dropout time delay	1~360s, Definite time	1s
Load monitor	Protection	On / Off	Off
	Method	Method 1 / Method 2	Method 1
	Current setting	$I_{c1}=0.5\sim 1I_r, I_{c1}\geq I_{c2}$	1.0I <sub>r</sub>
$I_{c2}=0.5\sim 1I_r, I_{c1}\geq I_{c2}$		0.5I <sub>r</sub>	
System type		3 $\Phi$ 3W3CT / 3 $\Phi$ 4W3CT / 3 $\Phi$ 4W4CT	3P : 3 $\Phi$ 4W3CT 4P : 3 $\Phi$ 4W4CT
Frequency		50Hz/60Hz	Fn
Power direction		P+ or P-	P+
Current requirement measure time window		5~60min	15min
Power requirement measure time window		5~60min	15min
Contact	Contact 1	26 status	Instantaneous
	Contact 2		Short circuit
Password		0000~9999	1234
Parameter lock		Unlock / Lock	Unlock
Language		Simplified Chinese / Traditional Chinese / English	English
Communication Baud rate		4800 / 9600 / 19200 / 38400bps adaptive	9600bps
Communication address		001~247	001
Communication mode		Local / Remote	Local

Note: 1. Factory setting parameter is different for different type of controller.

2. Factory setting can be customizing for different needed.

## 7. Secondary Wiring Diagram

### 7.1 Controller and Circuit Breaker Wiring

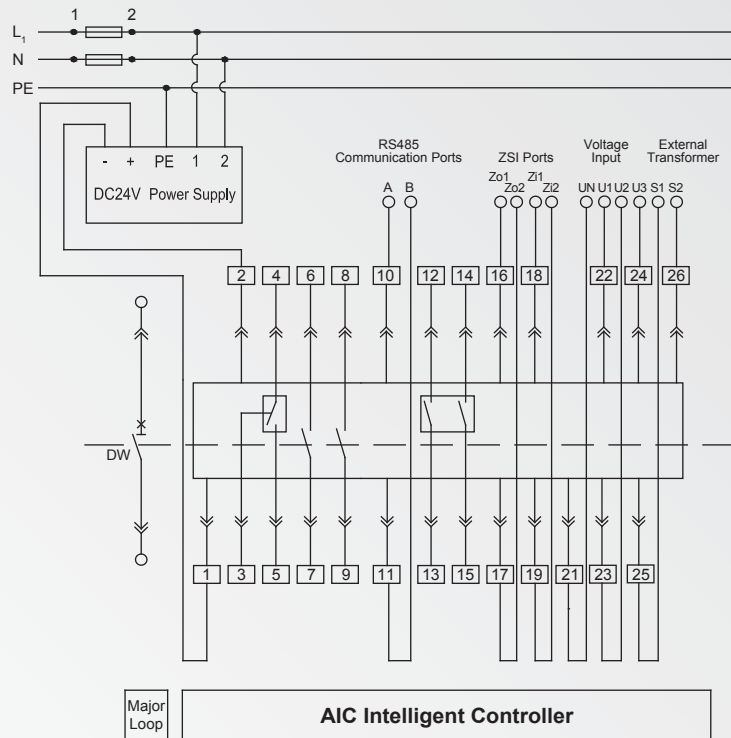

■ **1 # , 2 # :**

Working power supply input with DC24V, 1 # is positive and 2 # is negative.

■ **3 # , 4 # , 5 # :**

Fault tripping contact, passive output. When no fault tripping occurred, 3# and 4# is closing output, 4# and 5# is open output. Contact capacity is AC1/AC380V/2A, DC1/DC250V/0.3A.

■ **6 # , 7 # :**

Status auxiliary contact, passive output. Breaker at closing mode is closing output, open mode is open output. Contact capacity is AC1/AC380V/2A, DC1/DC250V/0.3A.

■ **8 # , 9 # :**

Status auxiliary contact, passive output. Breaker at closing mode is closing output, open mode is open output. Contact capacity is AC1/AC380V/2A, DC1/DC250V/0.3A.

■ **10 # , 11 # (for AIC-HC type) :**

RS485 communication outlet, 10 # is terminal A, 11 # is terminal B.

■ **12 # , 13 # (for AIC-H type):**

First set of programmable contacts, passive output, normal open. Contact capacity is AC1/AC250V/2A, DC1/DC30V/2A.

■ **14 # , 15 # (for AIC-H type):**

Second set of programmable contacts, passive output, normal open. Contact capacity is AC1/AC250V/2A, DC1/DC30V/2A.

■ **16 # , 17 # (for AIC-H type):**

ZSI output, Zo1, Zo2.

■ **18 # , 19 # (for AIC-H type):**

ZSI input, Zi1, Zi2.

■ **21#, 22#, 23#, 24# (for AIC-H type):**

3 phase voltage input, UN、U1、U2、U3.

Note: a. Phase sequence cannot be wrong.

b. 3 phase 4 wires system, UN must be connect.

c. 3 phase 3 wire system, UN and U2(B) must be shorted.

■ **25 # , 26 # ( for leakage protection or 3P+N):**

input terminal for external transformer, N phase external CT or leakage ZCT

Note: a. for leakage protection, only use for ZCT input terminal.

b. for 3P+N, only use for external sensor for neutral input terminal.

## 7.2 Secondary Wiring Diagram

### 7.2.1 AIC-E/A Type Controller

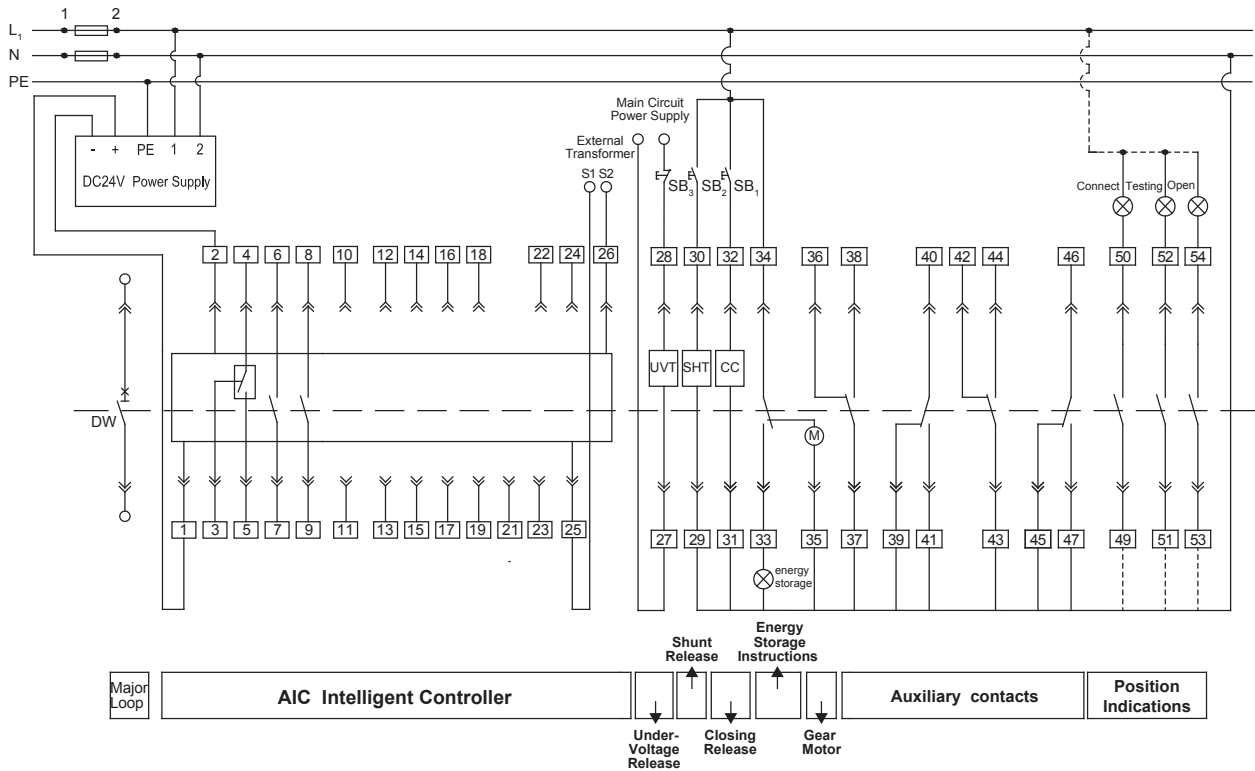

### 7.2.2 AIC-H Type Controller

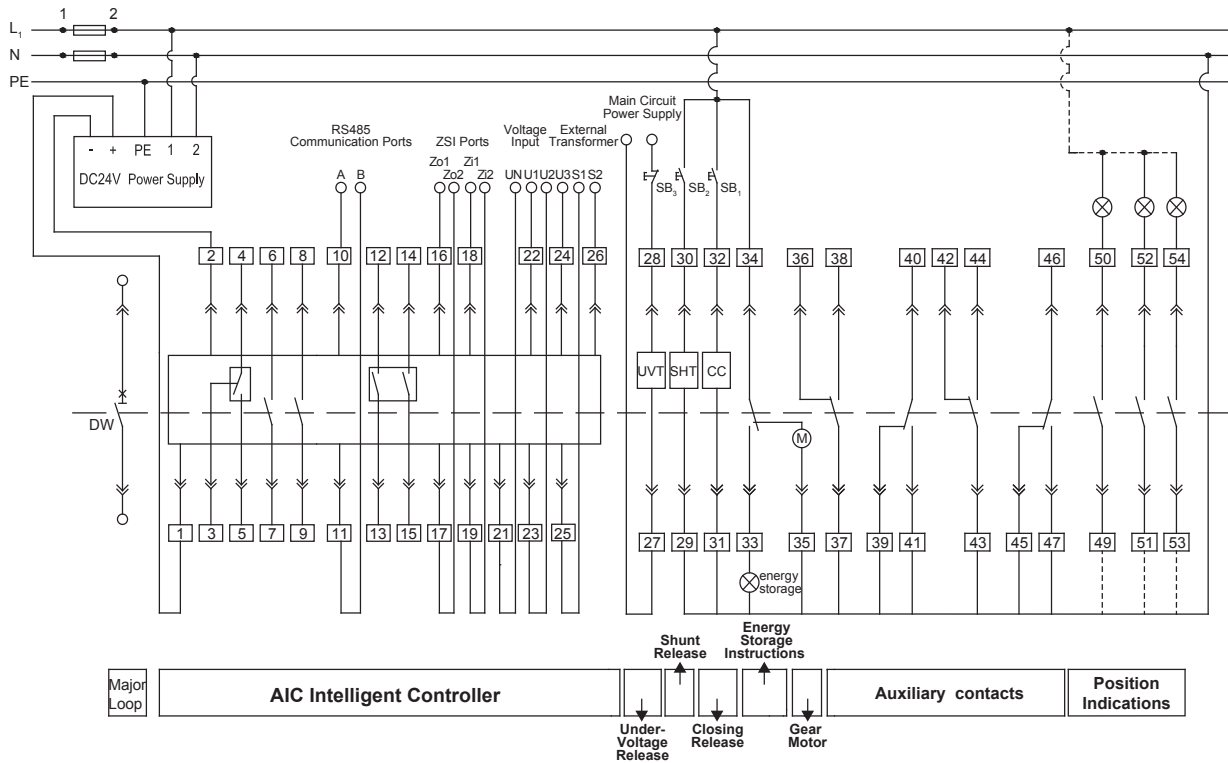

Note: (1) If CC, SHT and M are using different control voltage, they should connect to different power source.

(2) Terminal 35 and directly connect to power (automatic charging), or connect to a normally open button then connect to power (manual charging)

### 7.2.3 Remote Control Secondary Wiring

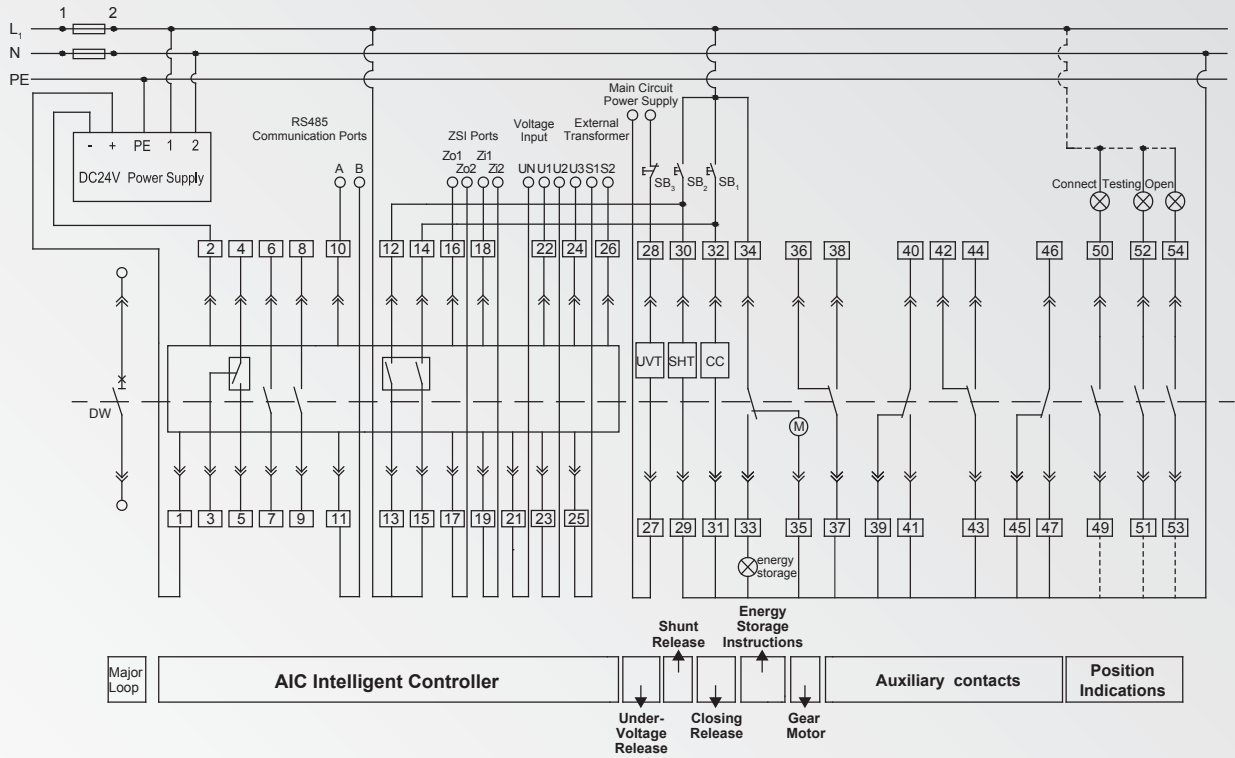

Note: Set the first set of programmable contact (12 # , 13 # )"remote open" and pair with a SHT ; set the second programmable contact (14 # , 15 # ) to "remote close" and pair with a CC ; then use the controller to send out signal for remote control.

## 8. Accessories and functions

### 8.1 Mechanical interlock

- Use for 2 set of ACB for horizontal connection, shown on the right.
- Maximum distance is 2000mm.
- The interlock can be install following the manual from manufacture.

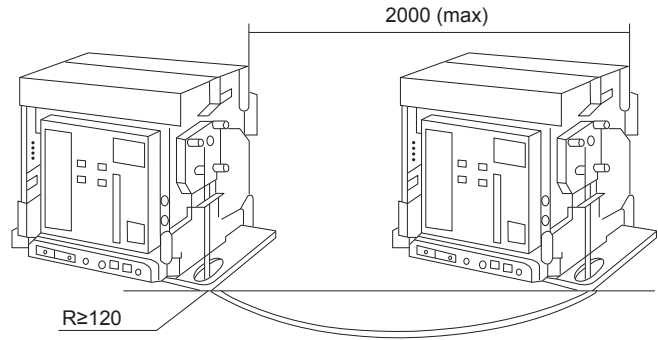

### Vertical installation combination

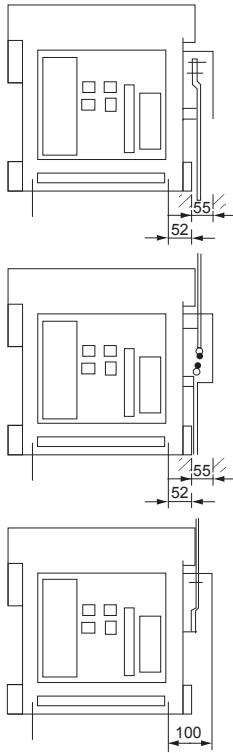
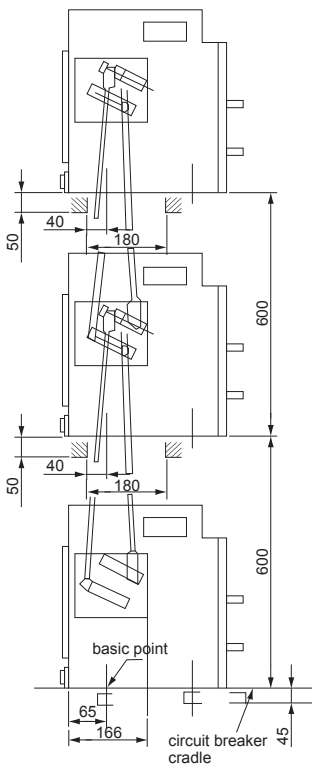

#### ■ 2 breakers

Backup	Normal
ACB 1	ACB 2
0	0
0	1
1	0

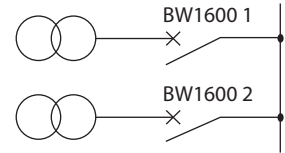

#### ■ 3 breakers

Backup	Normal	Normal
ACB 1	ACB 2	ACB 3
0	0	0
1	0	0
0	1	0
0	0	1

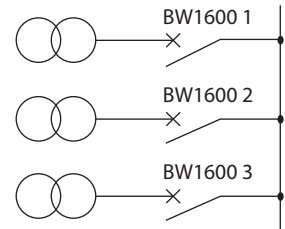

#### ■ 3 breakers

Backup	Normal	Normal
ACB 1	ACB 2	ACB 3
0	0	0
1	0	0
0	1	0
0	0	1

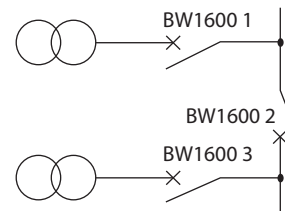

"Open" position lock (shown on the right)

"Open" position lock can lock the breaker at open position and prevent it from closing.

Can be choosing form:

- (1) 1 breaker with 1 set of lock and key
- (2) 2 breakers with 2 locks and 1 key
- (3) 3 breakers with 3 locks and 2 keys



## 8.2 Door Frame

- Install on the door for sealing purpose with protection level of IP40.
- Draw out type and fixed type to choose from, both are 11mm thick

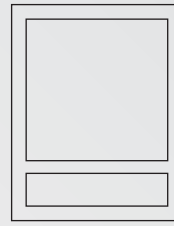

Draw out

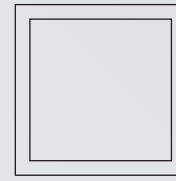

Fixed

## 8.3 Door Interlock

- Use to interlock the breaker and the door, to prevent the door be open at "connected" position.
- Right and left installation to choose from.

## 8.4 Under voltage release

- Break the breaker when the voltage is below 35%~70% of rated operation voltage.
- Tripping time: Instantaneous, time delay 1, 3, 5s  $\pm$  10%
- The coil cannot close the breaker without excitation, only reset when the voltage is back to 80% of rated operation voltage.
- Suction acid type and self-priming type to choose form.

### 8.5 Power Module

Transform external power source to DC24V via power module to supply to intelligent controller. Connect to secondary wiring terminal 1# and 2#. 1# is positive and 2# is negative.  
 Installation method 1: The standard guide way with 35mm in width inside the switchgear cabinet  
 Installation method 2: M4 screws installation

Input voltage (V)		Output voltage (V)	Output current(A)
AC/DC	100~240	DC 24 ± 5%	0.3
AC	380~415		
DC	24~60		

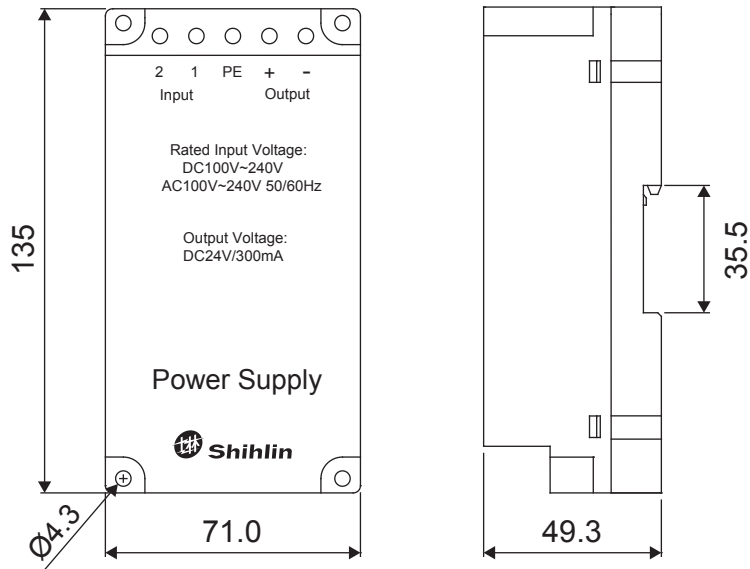

### 8.6 External sensor for neutral conductor (for 3P+N)

It is used together with circuit breaker with three poles in the power distribution system of TN-S and installed on the neutral conductor with 2m at maximum far from the installation point. Connect to secondary wiring terminal 25# and 26#.

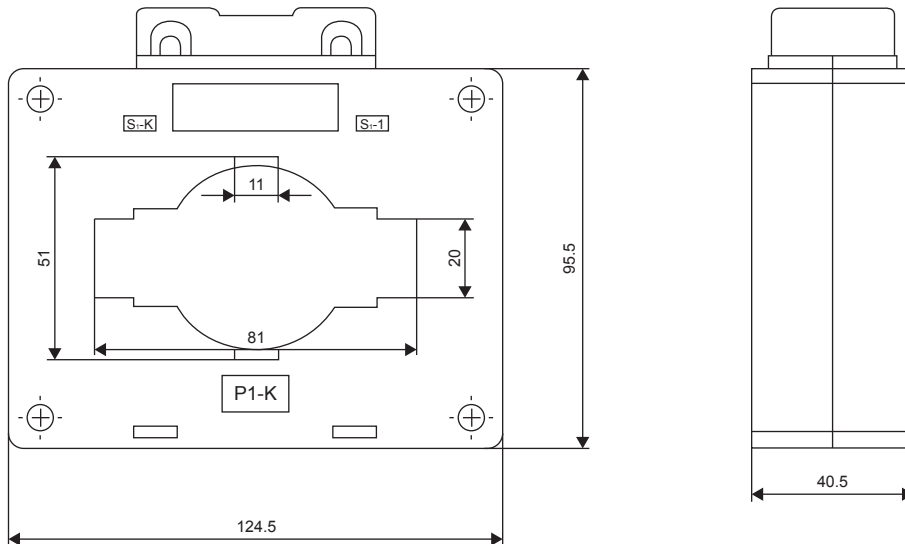

### 8.7 Zero-phase sequence current sensor (ZCT)

Rectangular sensor enables the detection of zero-phase sequence current which is required for the earth-leakage protection. It is installed around the bus-bars (phases + neutral). Ratio: 30A : 300mA.

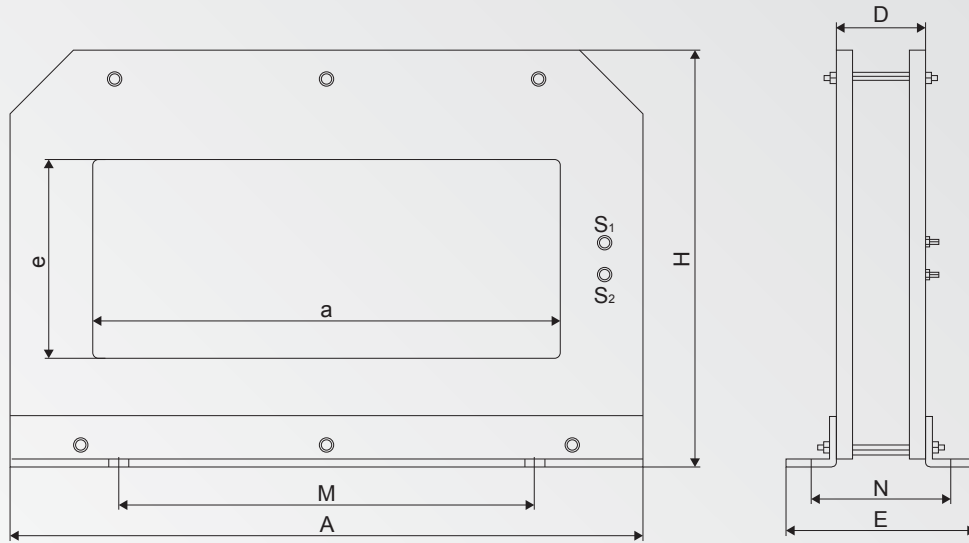

Type	Shape				Bore		Install	
	A	H	D	E	a	e	M	N
BH-LMB-280 % 120	380	250	54	114	285	120	250	72

### 8.8 External units of transformer's center

Use for Ground fault (Source ground return) protection.

■ External sensor of transformer's center (ratio 1In:1A)

It is used together with three-phase circuit breakers or four-phase circuit breakers in TN-S distribution system. The sensor is installed around the connection of the transformer neutral point to earth and connected to intelligent circuits via a module to provide the source ground return protection.

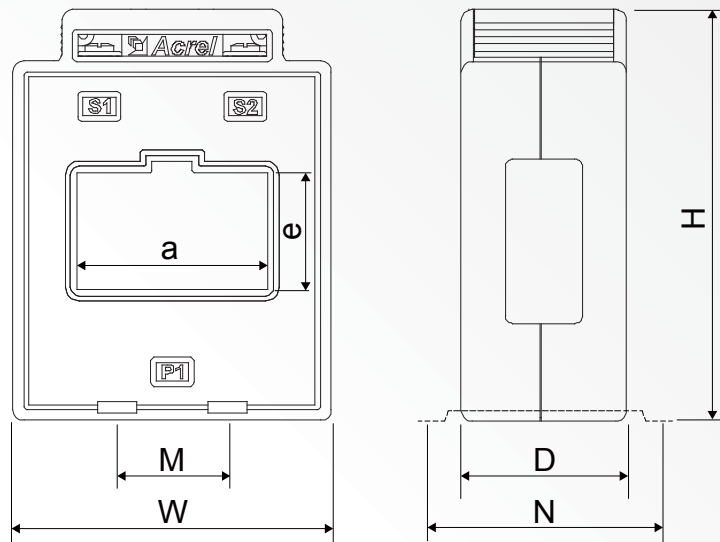

Standard	Size	Shape			Bore		Install	
		W	H	D	a	e	M	N
	60II	102	125	45	61	33	42	57.5



■ External module of transformer's center

S1 and S2 connect with the external sensor of transformer's center and S3 and S4 connect with terminals 25# and 26# of the secondary circuit. The module is installed by getting stuck to the standard guide way with 35mm in width inside the switchgear cabinet.

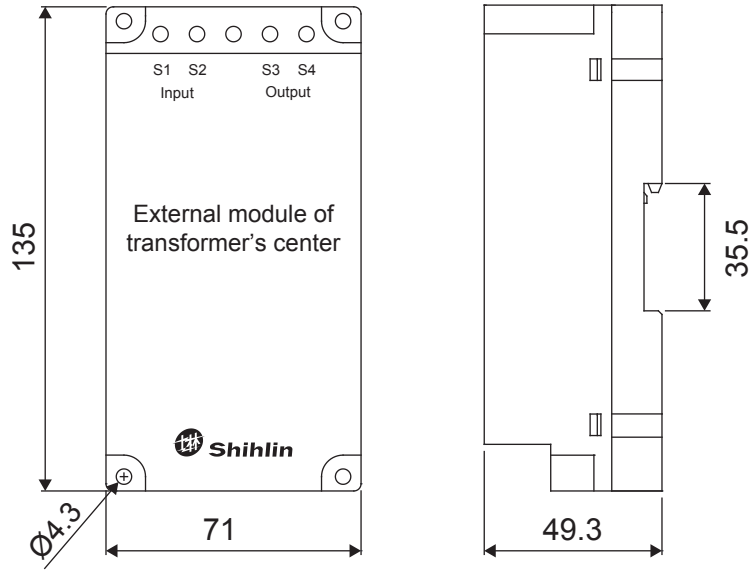

## 9. Safety Distance

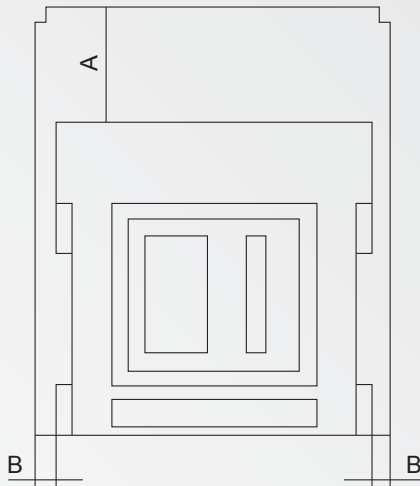

Draw-out Type

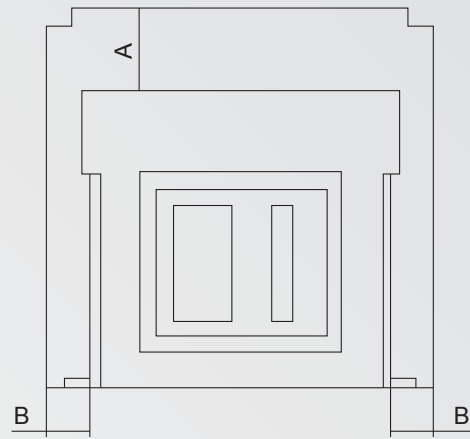

Fixed Type

	To insulator		To metal	
	A	B	A	B
Draw out	0	0	0	0
Fixed	0	30	0	70

## 10. Temperature Compensate

Ambient temperature		+40°C	+45°C	+50°C	+55°C	+60°C
Continued capacity	Inm : 1600A	1In	0.96In	0.92In	0.87In	0.8In

## 11. Busbar Dimension

Model	BW1600-SN						
	200A	400A	630A	800A	1000A	1250A	1600A
Thickness mm	5	5	5	5	5	5	10
Width mm	20	50	40	50	40	40	50
Number for each pole	1	1	2	2	3	4	2

Note: the data above is according to standard IEC60947-1.

## 12. Secondary Wiring Diagram

### 12.1 Draw out type (Unit : mm)

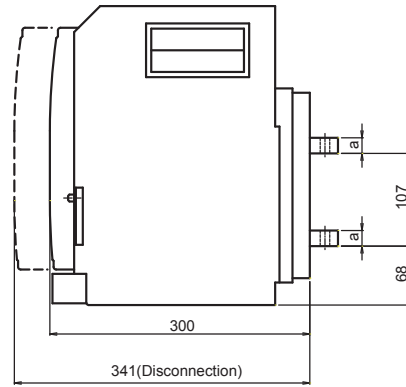
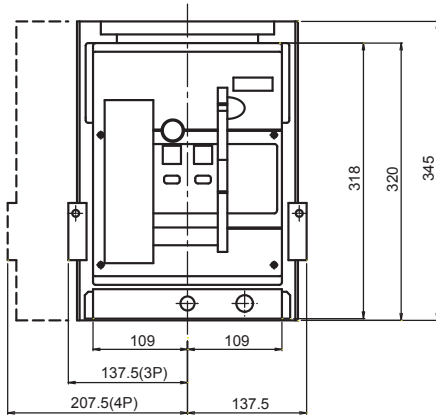

In	a (mm)
400-1000A	10
1250, 1600A	18

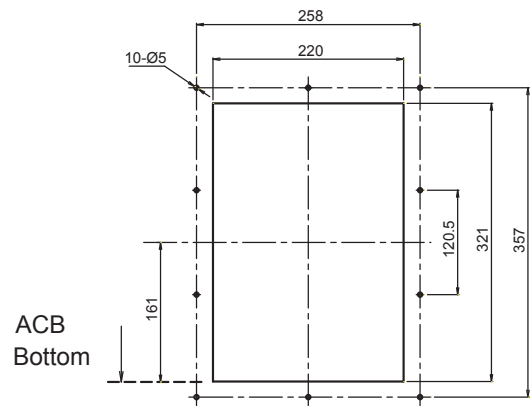
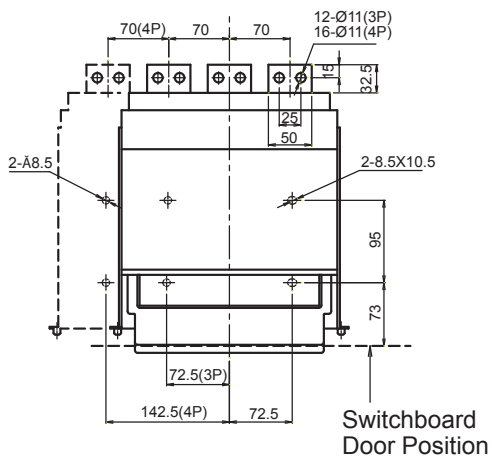

Door Frame Dimensions

12.2 Fixed type (Unit : mm)

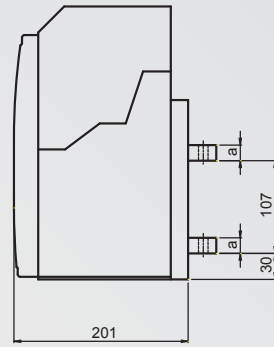
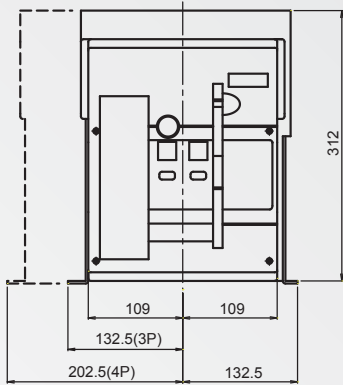

In	a (mm)
400-1000A	10
1250, 1600A	18

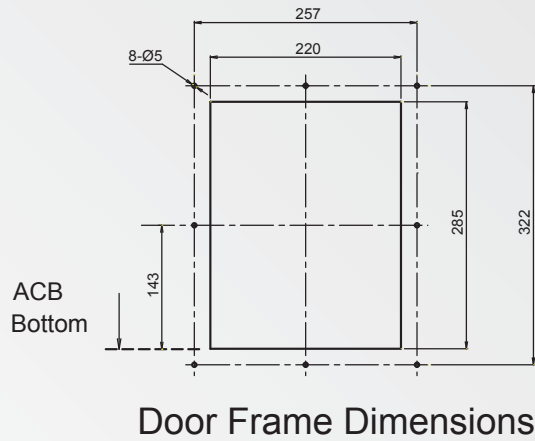
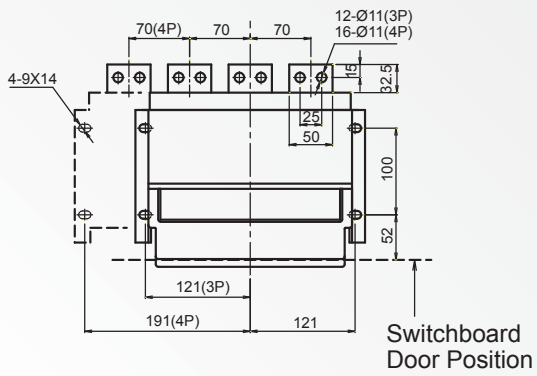

## 13. Mounting, Usage, and Maintenance

### 13.1 Mounting

- Before mounting, check the specifications of the circuit breaker to make sure if they meet the requirements.
- Before mounting, check the insulator resistance with a 500V megger. The resistance should not be less than 10MΩ when the surrounding medium temperature is 20°C +5°C with a relative humidity between 50% and 70%. If not, please dry it until the insulator resistance satisfies the requirements.
- The base of the breaker should be installed horizontally and —fixed by M10 screws.
- Circuit breakers should have reliable ground fault, and the ground fault points should be clearly marked. Fixed-type circuit breakers should strictly follow safe distance regulations.
- After mounting a circuit breaker according to the wiring diagram, the circuit breaker should be tested for the following matters before the main circuit is powered (for a drawer-type of circuit breaker, follow the instructions on the cradle for testing).
  - A. Check if the under-voltage, shunt release and closing electromagnet have well matched electric motor operation voltage (the breaker cannot be operated unless the under-voltage release is closed).
  - B. Energy-storage will be indicated after tripping the handle on the cover seven times. When hearing a click sound, energy storing is completed. Press the closing button or turn o-the electromagnetic switch to securely close the circuit breaker. Flip the handle again to start energy storage.
  - C. Turn on the power of electric motor energy storage device and"energy storage"will be displayed. There will be a click sound when energy storage is completed. The motor will be turned o-automatically. Press the"closing"button or closing the electromagnetic switch for closing the circuit breaker reliably.
  - D. When the breaker is closed in a tripping test (See 8.2.3d), the circuit breaker should be tripped by the tripping button of under-voltage or the release shunt or the tripping button on the cover.

## 13.2 Commonly Problem and Trouble-shooting

No	Problem	Possible causes	Troubleshooting
1	Circuit breaker can not be closed	<ul style="list-style-type: none"> <li>● Under voltage release is active.</li> <li>● Intelligent controller has not been reset.</li> <li>● Operation mechanical has no energy storage.</li> <li>● Draw out type is not in "connect" or "testing" position.</li> <li>● "Open" lock is in lock.</li> </ul>	<ul style="list-style-type: none"> <li>● Check the wiring, and turn on the power of under voltage release.</li> <li>● Press the reset button.</li> <li>● Manual charging.</li> <li>● Use the handle and operate the breaker to "connect" or "testing" position.</li> <li>● Use the key to unlock.</li> </ul>
2	Circuit breaker cannot use automatic charging	<ul style="list-style-type: none"> <li>● Power of the electric operation machine is not on.</li> <li>● Insufficient power capacity.</li> </ul>	<ul style="list-style-type: none"> <li>● Check the wiring, and turn on the power.</li> <li>● Check if the operating voltage is greater than 85%Us.</li> </ul>
3	Closing release does not close the breaker	<ul style="list-style-type: none"> <li>● No power / no voltage.</li> <li>● Insufficient power capacity.</li> </ul>	<ul style="list-style-type: none"> <li>● Check the wiring, and turn on the power.</li> <li>● Check if the operating voltage is greater than 85%Us.</li> </ul>
4	Shunt release does not open the breaker	<ul style="list-style-type: none"> <li>● No power/ no voltage.</li> <li>● Insufficient power capacity.</li> </ul>	<ul style="list-style-type: none"> <li>● Check the wiring, and turn on the power.</li> <li>● Check if the operating voltage is greater than 85%Us.</li> </ul>
5	Breaker frequently tripping	<ul style="list-style-type: none"> <li>● Under voltage frequently.</li> <li>● On-site overloading causing the overload protection.</li> </ul>	<ul style="list-style-type: none"> <li>● Check the voltage should be within 85%~110%Ue.</li> <li>● Adjust Ir value or change the rated current In.</li> </ul>
6	Draw out type breaker's handle cannot be inserted	<ul style="list-style-type: none"> <li>● The track of the cradle or the circuit breaker itself is not pushed incompletely.</li> </ul>	<ul style="list-style-type: none"> <li>● The track or the circuit breaker has to be pushed all the way to the end.</li> </ul>
7	The breaker cannot be pulled out from the body of draw out type circuit breaker at "disconnected" position	<ul style="list-style-type: none"> <li>● The handle was not pulled out completely.</li> <li>● The circuit breaker is not completely disconnected.</li> </ul>	<ul style="list-style-type: none"> <li>● Pull out the handle.</li> <li>● Make the circuit breaker to the "disconnected" position completely.</li> </ul>



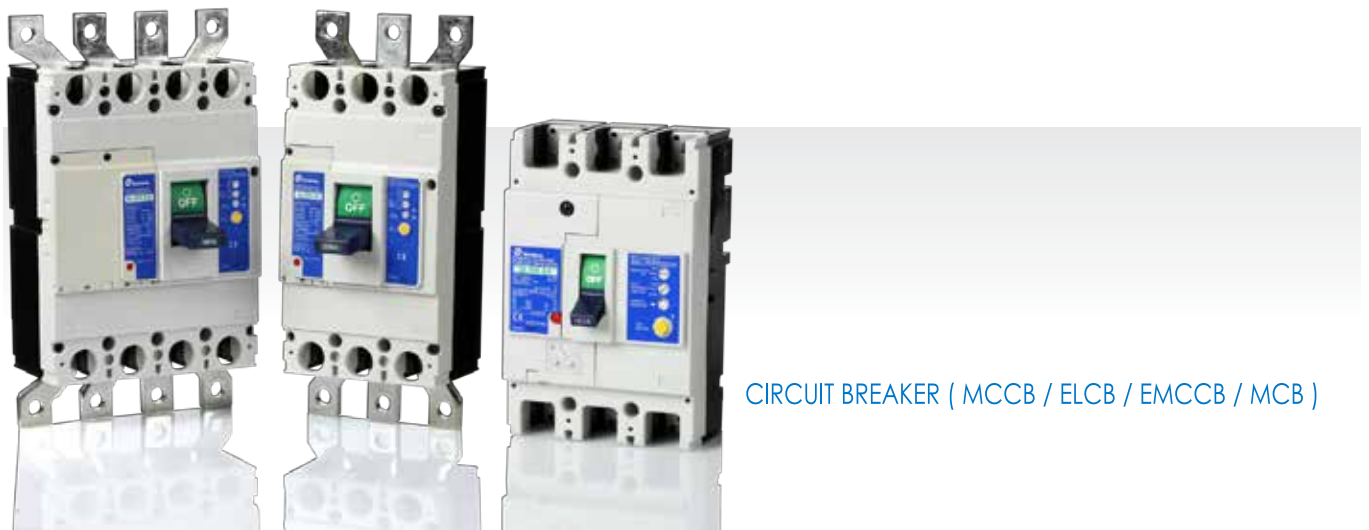

CIRCUIT BREAKER ( MCCB / ELCB / EMCCB / MCB )

## Breaker & Switchgear System



AIR CIRCUIT BREAKER

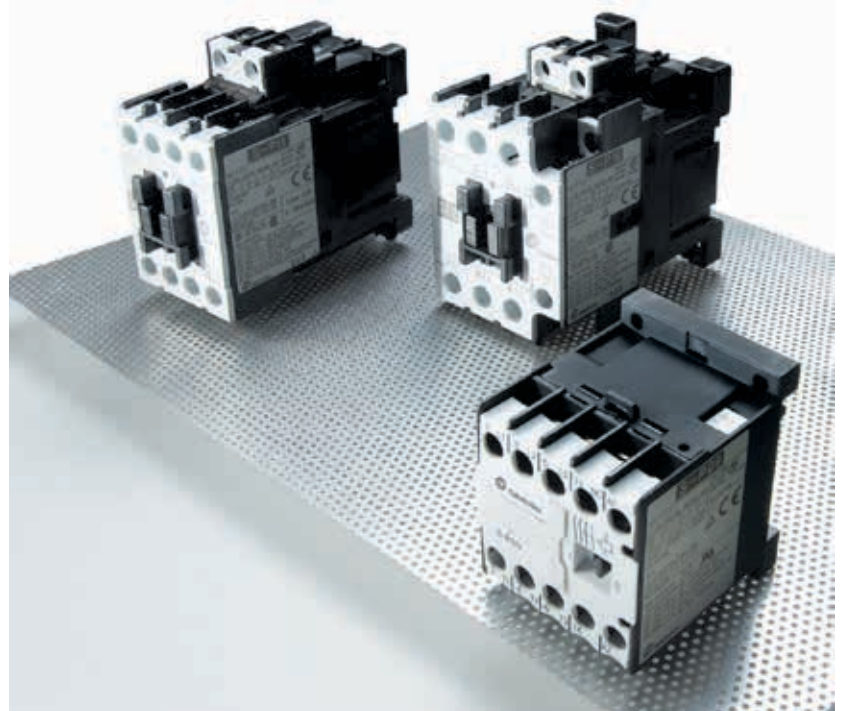

MAGNETIC CONTACTOR / SWITCH ( CONTACTOR / MS / MMS )



AUTOMATIC TRANSFER SWITCHES



SURGE PROTECTIVE DEVICE



SMART METER



INVERTER



LOW VOLTAGE POWER CAPACITORS





# SHIHLIN ELECTRIC & ENGINEERING

MOTOR CONTROL (CONTACTOR/ MS/ MMS), CIRCUIT BREAKER (MCCB/ ELCB/ EMCCB/ MCB), AIR CIRCUIT BREAKER, AUTOMATIC TRANSFER SWITCHES (Panel Board Type/ Residential Unit Use), SURGE PROTECTIVE DEVICE, LOW VOLTAGE POWER CAPACITORS, SMART METER, INVERTER



## **Breaker & switchgears overseas sales dept.**

3F, No.9, Sec. 1, Chang-an E. Rd., Zhongshan Dist., Taipei City 10441, Taiwan

T. +886-2-2541-9822 F. +886-2-2581-2665

e-mail. [b.export@seec.com.tw](mailto:b.export@seec.com.tw)

<http://circuit-breaker.seec.com.tw>

## **Headquarter**

16F, No.88, Sec. 6, Zhongshan N. Rd., Shilin Dist., Taipei City 11155, Taiwan

T. +886-2-2834-2662 F. +886-2-2836-6187

<http://www.seec.com.tw>

Distributor

B180411E.ACB-1600-OB